



n and

de

THESE INSTRUCTIONS ARE TO BE LEFT WITH THE USER

Contents

Section	Page
1 Introduction	3
2 Important Safety Information	4
3 Pack Contents Checklist	5
4 Dimensions	7
5 Specifications	8
6 Installation Requirements	9
7 Installation	14
8 Commissioning	29
9 Operation	33
10 Fault Diagnosis	35
11 Maintenance	41
12 Spare Parts	46
13 Accessories	50
Guarantee, Customer Care Policy, and How to contact us	Back cover

Thank you for purchasing a quality Mira product. To enjoy the full potential of your new product, please take time to read this guide thoroughly, having done so, keep it handy for future reference.

The Mira CombiForce 415 is a pressure balanced shower control which maintains a constant **outlet temperature** irrespective of changes in **inlet pressures** as long as the **inlet water temperatures** remain the same. It is not a thermostatic shower control and does not sense supply temperature variations. Therefore, inlet water temperatures especially the hot, should remain relatively constant.

The Mira CombiForce 415 can be installed with the following packages:

- Fully modulating multipoint gas water heaters.
- Fully modulating combination boilers.
- Unvented mains pressure systems.
- Mains pressurised, instantaneous hot water heated from thermal store, systems.
- Pumped systems.

Showering temperature is adjusted by the shower control. The flow rate is determined by the supply pressures available at the inlets, and the output rating of the heater appliance.

Shower controls covered by this guide:

Mira CombiForce 415

Surface mounted pressure balanced shower control for connection to **exposed pipework**, for **high pressure** applications (**1.0 – 5.0 bar**). Available in white/chrome, white/light golden or all chrome finish.

Mira CombiForce 415B

Built-in shower control for connection to **concealed pipework**, for **high pressure** applications (**1.0 – 5.0 bar**). Available in white, white/chrome, white/light golden or all chrome finish.

If you experience any difficulty with the installation or operation of your new shower control, then please refer to **Section 10, "Fault Diagnosis"**, before contacting Kohler Mira Limited. Our telephone and fax numbers can be found on the back cover of this guide.

Warning!

1. Products manufactured by us are safe and without risk provided they are installed, used and maintained in good working order in accordance with our instructions and recommendations.

Caution!

1. Read all of these instructions.
2. Retain this guide for later use.
3. Pass on this guide in the event of change of ownership of the installation site.
4. Follow all warnings, cautions and instructions contained in this guide.
5. The plumbing installation must comply with the requirements of UK Water Regulations/Byelaws (Scotland), Building Regulations or any particular regulations and practices, specified by the local water supplier. **The installation should be carried out by a plumber or contractor who is registered or is a member of an association such as:**
 - Institute of Plumbing (IOP), throughout the UK.
 - National Association of Plumbing, Heating and Mechanical Services Contractors (NAPH & MSC), England and Wales.
 - Scottish and Northern Ireland Plumbing Employers' Federation (SNIPEF), Scotland and Northern Ireland.
6. Anyone who may have difficulty understanding or operating the controls of any shower should be attended whilst showering. Particular consideration should be given to the young, the elderly, the infirm, or anyone inexperienced in the correct operation of the controls.

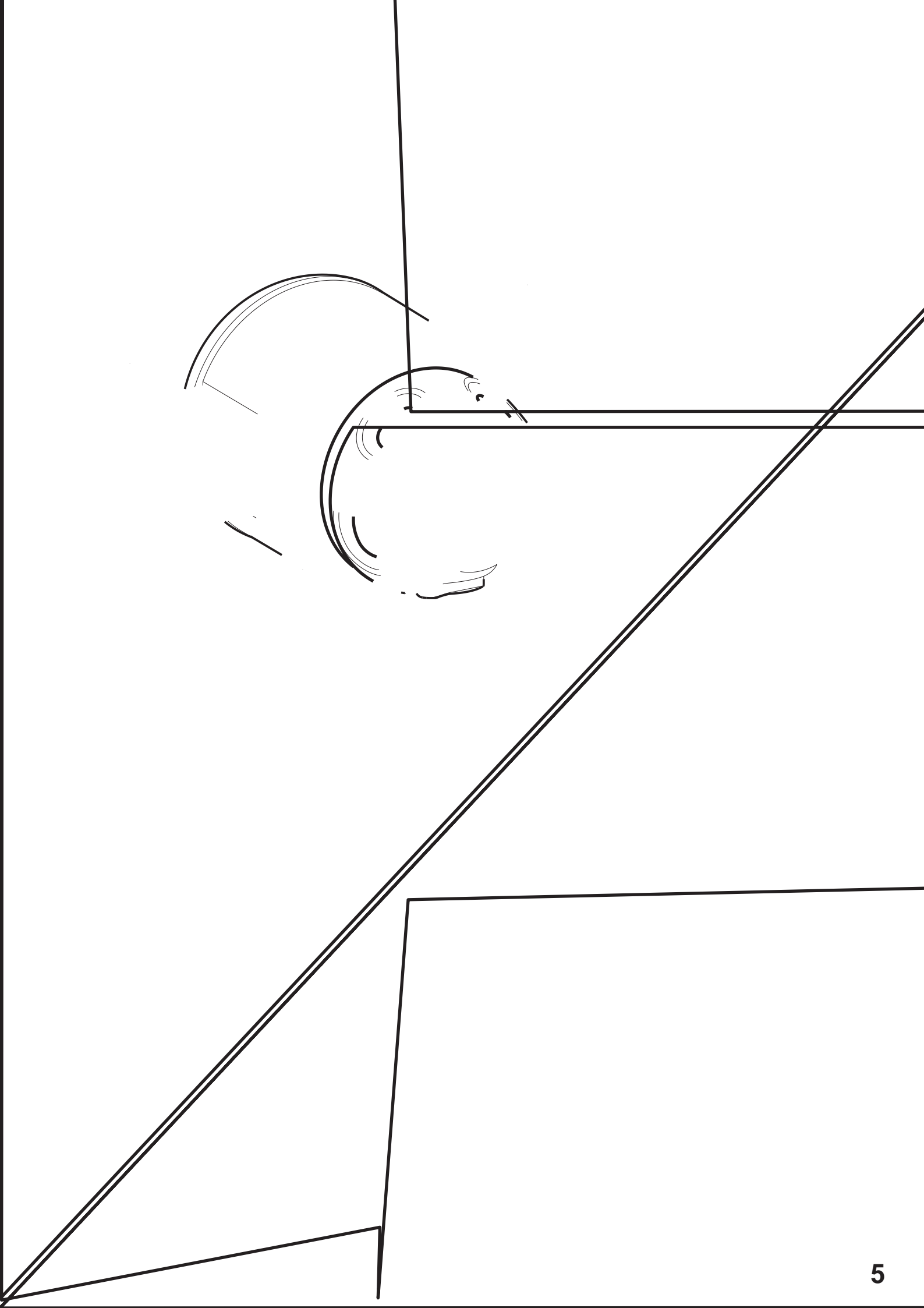

2. Mira CombiF

Shower Conf

o

o

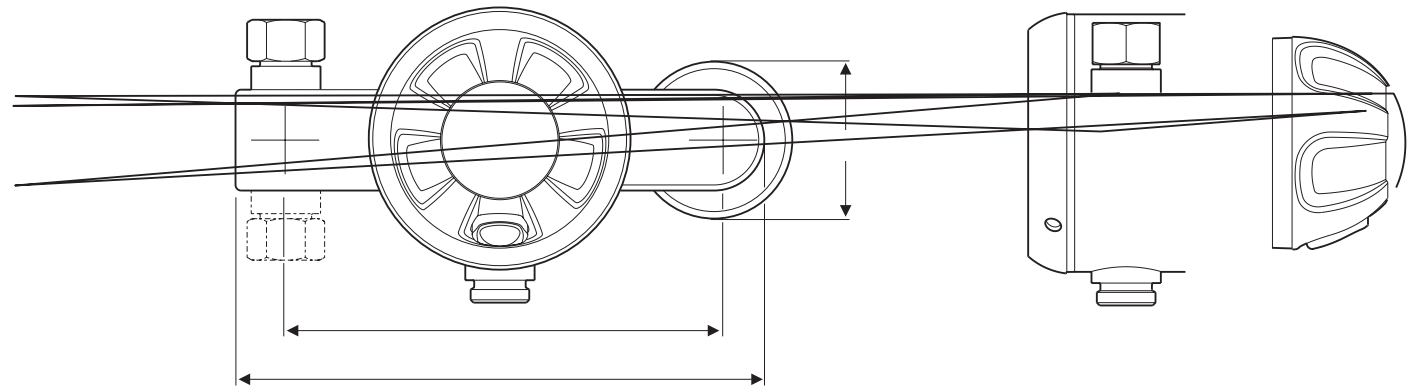

Mira CombiForce 415 and 415B

Pressure Range

Minimum maintained pressure: **1 bar**.

Maximum maintained pressure: **5 bar**.

Maximum static pressure: **10 bar**.

Note! For optimum performance, the initial supply pressures should be nominally equal.

Temperatures

Hot and cold water supply temperatures **MUST** remain relatively constant.

Maximum hot water temperature: **85°C**.

Ideally the hot water temperature should never exceed 65°C. A water temperature of 60°C is considered sufficient to meet all normal requirements and will minimize the deposition of scale in hard water areas.

Connections

Inlet

15 mm Compression or 1/2" BSP male (**CombiForce 415**).

15 mm Compression (**CombiForce 415B**).







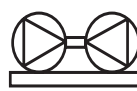

Outlet

1/2" BSP male (**CombiForce 415**).

15 mm Compression or 1/2" BSP male (**CombiForce 415B**).

1. Layout and sizing of pipework must be such that when other services are used, pressures at the shower control inlets do not fall below the recommended minimum (**1 bar**). The pressure balancing performance is impaired below 1 bar. When fitted with some heater appliances the minimum maintained pressure may be above 1 bar, refer to the section **Commissioning: “Multipoint gas water heaters”** or **“Combination boilers”**.
2. The Mira CombiForce 415 is **not suitable** for installation as part of a gravity-fed plumbing system (i.e. in conjunction with a hot water cylinder and cold water storage cistern), unless used in conjunction with an inlet pump producing a maintained pressure of at least 1 bar.
3. When used with a **fully modulating** multipoint or combination boiler **above 5 bar maintained pressure**, a pressure reducing valve will be necessary. For information on measuring system pressures refer to **Installation Requirements: “Measuring System Pressures”**. For further information on pressure reducing valves consult your local plumbing stockist.
4. Supply pipes **MUST** be flushed to clear debris before connecting the shower control.
5. Conveniently situated isolating valves **MUST** be fitted for servicing purposes.
6. If the shower control is to be used with a fully modulating multipoint water heater, fully modulating combination boiler, thermal store or unvented system an expansion vessel must be fitted to accommodate the expansion of water in the domestic hot water supply (this may already be part of the system, check the details on the boiler/heater or contact the boiler/heater manufacturer).
7. No form of outlet flow control should be fitted, only Mira recommended fittings should be used in the outlet pipework.

Key to symbols appearing throughout this guide.

	Float operated valve		Twin impeller inlet pump
	Stop or servicing valve		Tempering valve
	Shower control		Mini expansion vessel
	Warning or overflow pipe		Non-return Valve
	Drop tight pressure reducing valve (PRV)		

Typical Suitable Installations

1. Instantaneous multipoint water heaters and combination boilers

The shower **MUST** be installed with a multipoint gas water heater or combination boiler of a **fully modulating design** (i.e. where the water draw-off rate indirectly controls the gas flow rate to the burner).

An expansion vessel **MUST** be fitted (and regularly maintained) if any form of backflow prevention device is fitted, e.g. non-return valve, PRV. This will ensure that excess expansion or pulse pressures do not damage the product or the plumbing system. The expansion vessel may already be fitted within the boiler (check with the manufacturer) and is in addition to the normally larger central heating expansion vessel.

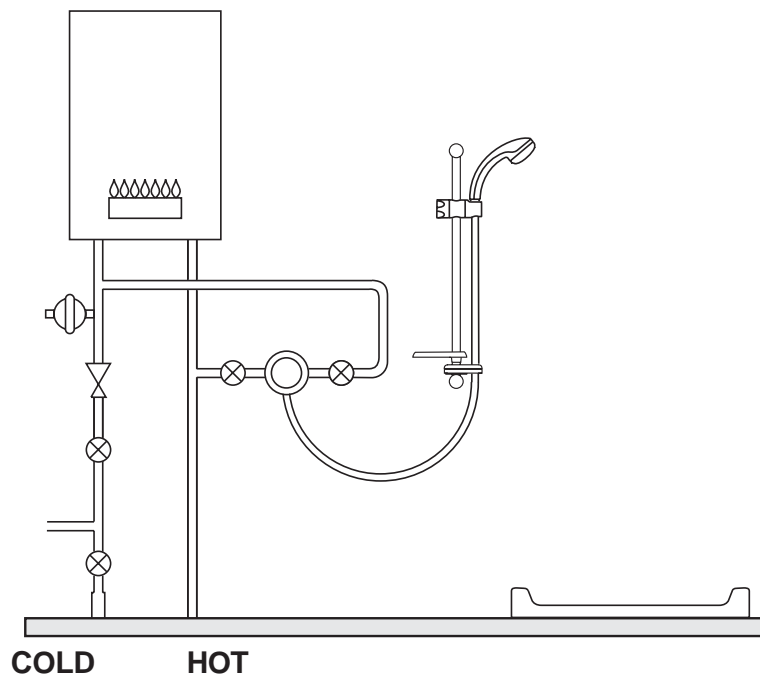

Figure 1

2. Unvented mains pressure showers

The shower can be installed with an unvented, stored hot water cylinder. Only a "competent person" as defined by the Building Regulations may fit this type of system.

For packages with no cold water take off after the appliance reducing valve, it will be necessary to fit an additional drop tight pressure reducing valve when the mains pressure is over 5 bar. The drop tight pressure reducing valve must be set at the same value as the unvented package pressure reducing valve.

Note! An expansion vessel **MUST** be fitted (and regularly maintained) if any form of backflow prevention device is fitted, e.g. non-return valve, PRV. This will ensure that excess expansion or pulse pressures do not damage the product or the plumbing system.

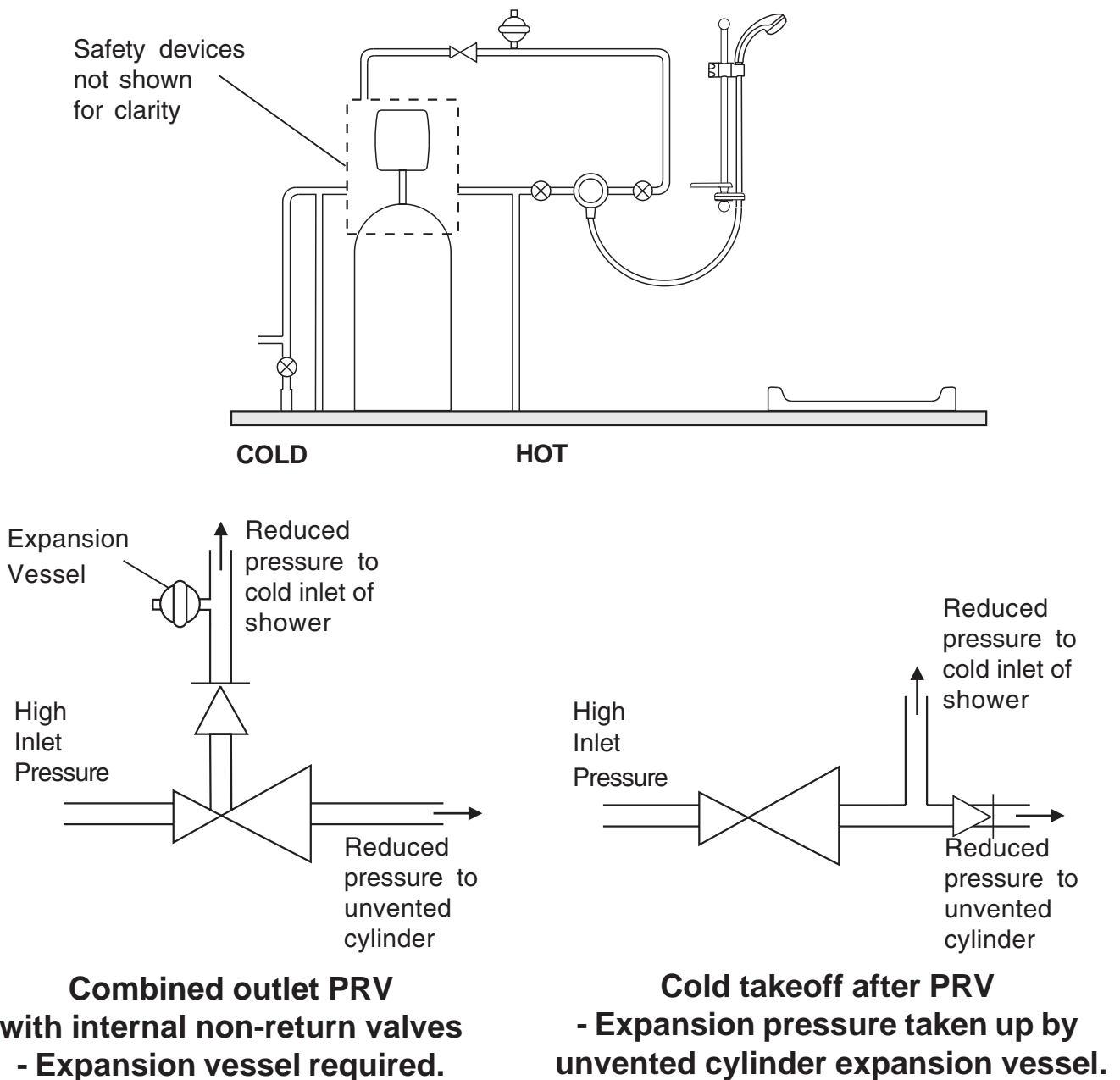

Figure 2

3. Mains pressurised instantaneous hot water shower, heated from a thermal store

Packages of this type, fitted with a tempering valve can be used.

A drop tight pressure reducing valve **MUST** be fitted if the supply pressures exceed 5 bar maintained.

An expansion vessel **MUST** be fitted (and regularly maintained) if any form of backflow prevention device is fitted, e.g. non-return valve, PRV. This will ensure that excess expansion or pulse pressures do not damage the product or the plumbing system. The expansion vessel may already be fitted externally or internally within the thermal store (check with thermal store manufacturer).

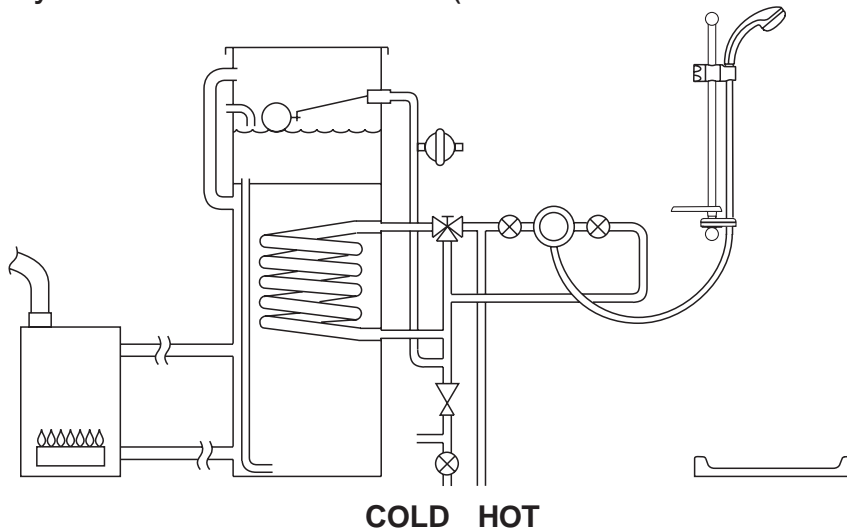

Figure 3

4. Pumped showers (inlet pumps)

The shower can be installed with an inlet pump (twin impeller). The pump **MUST** be located on the floor next to the hot water cylinder. The hot water cylinder/vent pipes must be arranged as shown to achieve air separation.

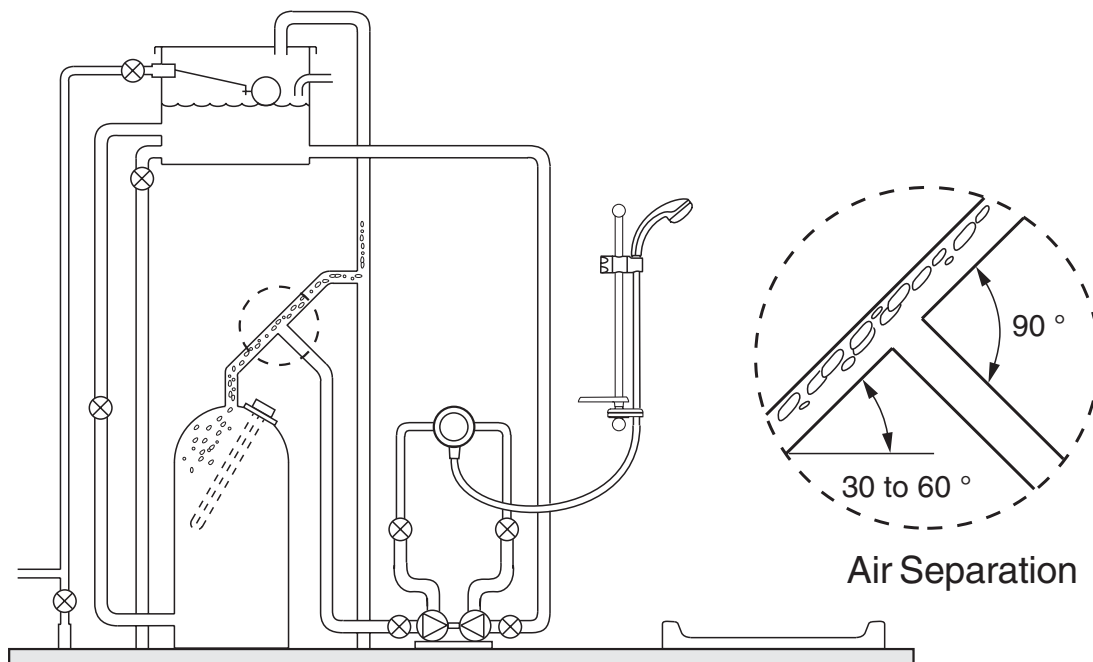

Figure 4

Measuring System Pressures

1. General

It is important that the system pressures are within the range specified for the Mira CombiForce 415 (refer to the **Specifications** section).

If the system pressure is not known then the system pressure **MUST** be measured as explained in this section.

Pressures are those present at the inlet to the appliance either whilst running (maintained) or in the off state (static). Nearby hot and cold taps connected to the same proposed feed pipes as the appliance can be used to measure the static pressure. No other fitting or appliance should be in use at this time.

Water pressures vary throughout the day, therefore you must ensure that water pressures do not drop below or exceed the minimum/maximum required (refer to the **Specifications** section).

2. To measure static pressure (Refer to Figure 5)

With the pressure testing device firmly connected to a tap drawing from one of the proposed feed pipes and the outlet from the device in the off position, the tap is turned on and the static pressure noted.

3. To measure maintained pressure (Refer to Figure 5)

The pressure testing device is connected as above, the taps turned on and the outlet from the device opened until a flow of around 5 l/min is obtained (this is easily done by timing the flow into a calibrated container). The maintained pressure which can be expected when the shower is in operation can then be read. This should be carried out on the hot and cold supply.

4. To measure pressure drop

Pressure drop results from another fitting being turned on when the shower is in use. Having checked the maintained pressure as in 3.3. and with the device still discharging at approximately 5 l/min, turn on a second draw-off from the same feed pipe. This new reading will show the pressure drop from 3.3. and should be above the minimum maintained pressure recommended by the manufacturer.

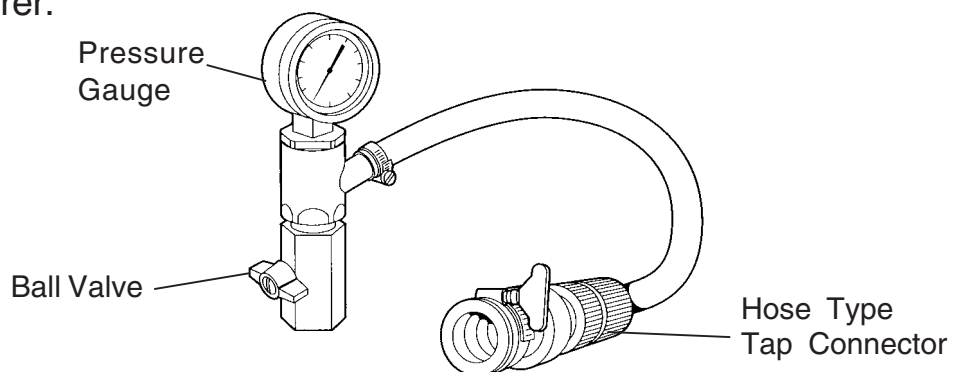

Pressure Testing Device
Figure 5

Mira CombiForce 415 Surface Mounted Shower Control

Rising or Falling Inlet Supplies

Note! The Mira CombiForce 415 is supplied with inlet connections **hot left, cold right** and **bottom outlet** as standard. For installations with reversed hot and cold supplies complete the installation and refer to the section **Installation: "Reversed Inlet Supplies"**.

1. Before you decide on the final position of your shower control, please bear in mind the following:

- Decide on a suitable position for the shower control. The position of the shower control and the shower fittings must provide a minimum gap of **25 mm** between the spill-over level of the shower tray/bath and the handset. This is to prevent backsiphonage.
- Determine whether the hot or cold water services will be connected to the shower control from the bottom (rising) or from the top (falling).

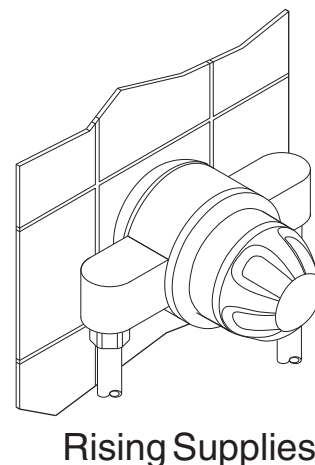
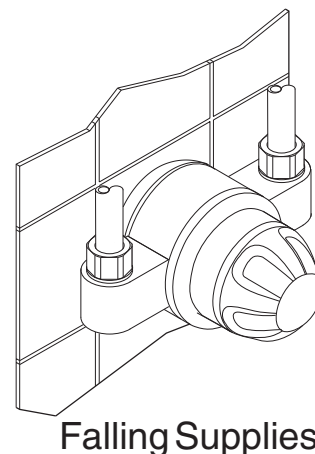
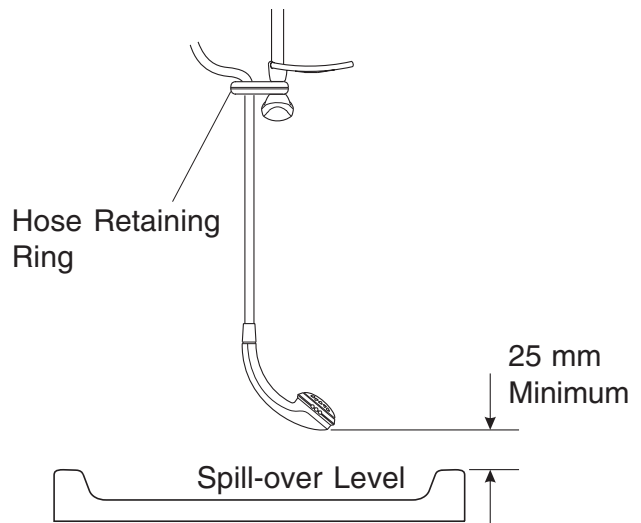

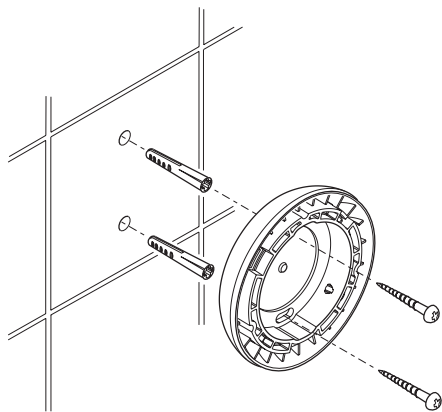
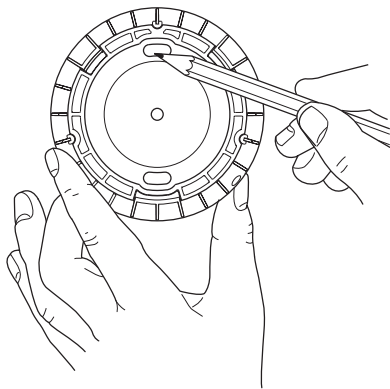
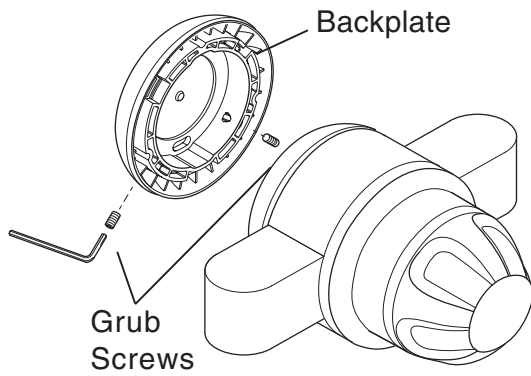

2. Remove the backplate by releasing, anticlockwise, the two recessed grub screws which retain the backplate against the brass shower control body, using the 2.5 mm A/F hexagon wrench (supplied).

3. Mark the final position of the shower control on the finished wall surface using the backplate as a template.

Mark the position of the two holes on the backplate. Ensure the holes are vertically aligned.

WARNING! Ensure there are no buried cables or pipes in the wall before drilling.

4. Drill the two marked fixing holes and fit the wallplugs provided. Secure the backplate to the wall with the two No. 8 x 1³/₄" fixing screws.

Note! Screws with larger heads will foul the shower control body.

5. Thoroughly flush the incoming hot and cold water supplies before connecting the shower control.

6. Release, anticlockwise, the two grub screws that retain the inlet elbows, using the 2.5 mm A/F hexagon wrench (supplied). **Ensure that the 'O' seal is correctly located on the smaller diameter shoulder of the brass inlet connector, and not in the 'V' groove.**

7. Fit the shower control body onto the backplate and secure by tightening, clockwise, the two recessed grub screws, using the 2.5 mm A/F hexagon wrench (supplied).

8. Refit the elbows in the required position, i.e. rising or falling supplies. Ensure the grub screws locate into the 'V' groove and tighten the grub screws.

9. Assemble the components of the inlet connector compression fittings in the following sequence for each inlet:-

9.1. Place the fibre gasket against the shoulder of the 1/2" BSP inlet connector nipple.

9.2. Screw, clockwise, the 1/2" BSP connector nipple into the elbow ensuring that the compression taper faces uppermost, using a 12 mm A/F hexagon wrench (not supplied).

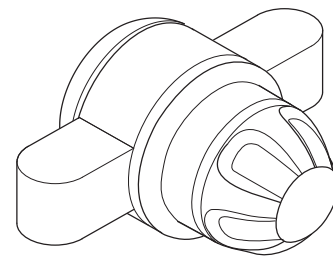
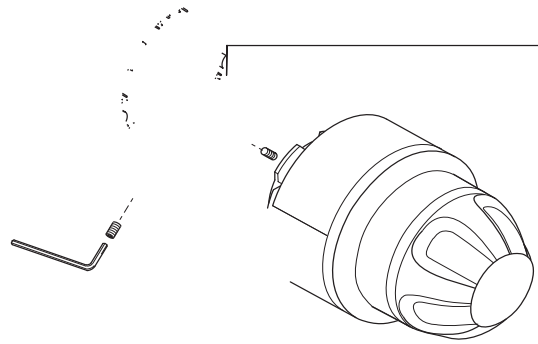

Rising Supplies

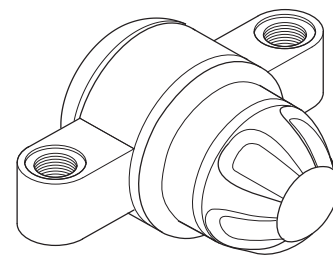

Falling Supplies

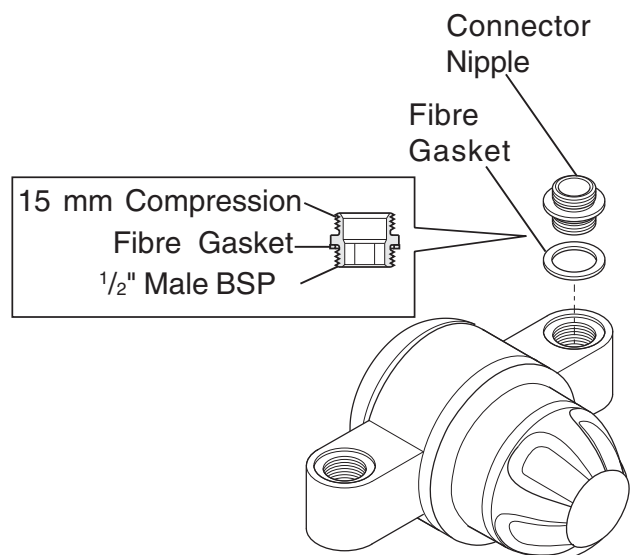

- 9.3.** Slide, in turn, the compression nut, then the olive, over the hot and cold inlet pipework. If necessary, sparingly, smear 'liquid jointing' on the pipe end and the outside of the olive.

Insert the hot and cold inlet pipework into the opening of the 1/2" BSP inlet connector nipple then slide the olive and compression nut into place.

- 9.5.** Finally, carefully tighten, clockwise, the compression nut. If necessary use a cloth to protect the plated surfaces.

- 10.** Fit the 'O' seal to the tapered end of the outlet nipple and screw it into the shower control outlet using a 12 mm A/F hexagon wrench (not supplied). This will leave the flat face for connection to the shower hose.

- 11.** This completes the installation of the **Mira CombiForce 415** for "Rising or Falling Inlet Supplies".

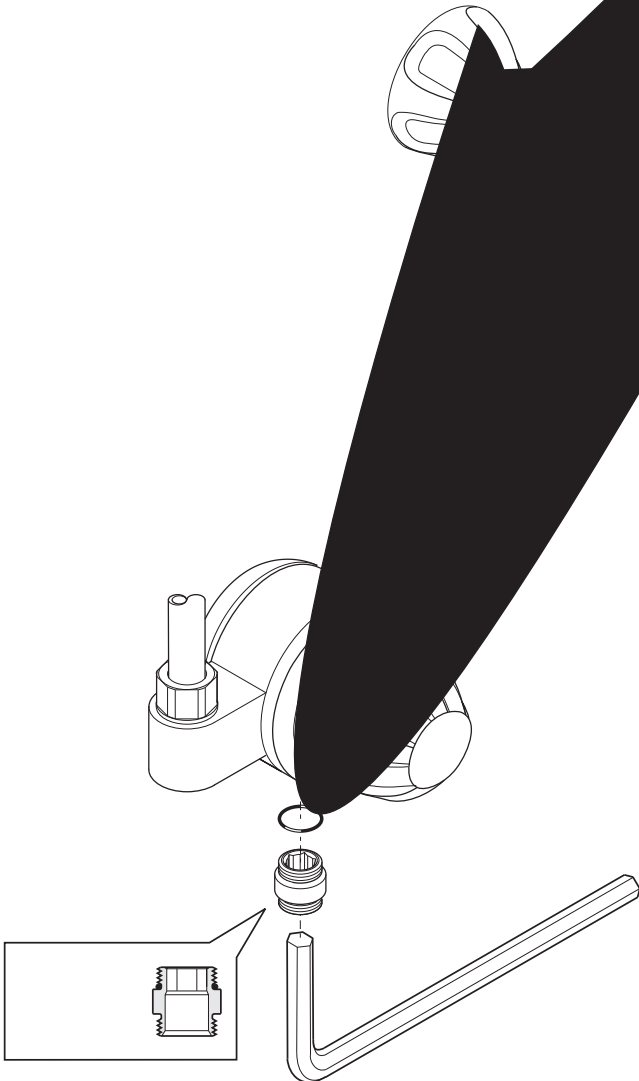

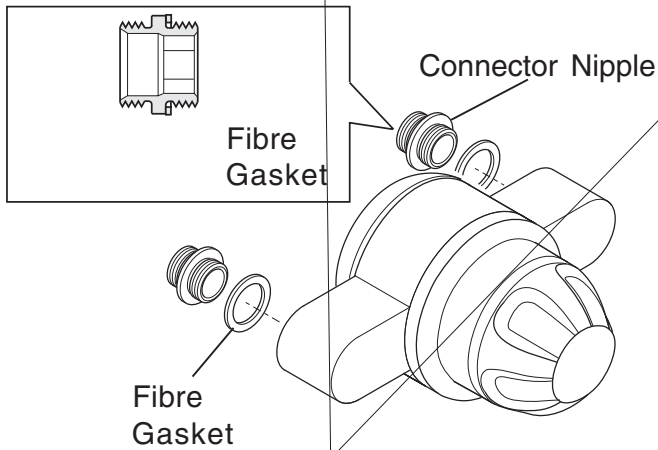

6. Fit the gaskets to the $\frac{1}{2}$ " BSP connector nipples and screw in the nipples with the tapered ends outermost to accept the compression fittings. Tighten the $\frac{1}{2}$ " BSP connector nipples fully with a 12 mm A/F hexagon wrench (not supplied).

7. **Thoroughly flush the incoming hot and cold water supply pipes before connecting the shower control.** Failure to do so may result in product malfunction.

8. Slip the compression nuts and olives over the supply pipes.

9. Locate the shower control body onto the backplate and inlet supply pipework, then secure by tightening, clockwise, the two recessed grub screws, using the 2.5 mm A/F hexagon wrench (supplied).

Tighten the compression nuts, using if necessary, a cloth to protect the plated surfaces.

Turn on the water supplies and check for any leaks!

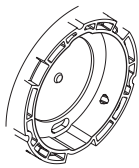

10. Fit the 'O' seal to the tapered end of the outlet nipple and screw it into the shower control outlet using a 12 mm A/F hexagon wrench (not supplied). This will leave the flat face for connection to the shower hose.

11. This completes the installation of the Mira CombiForce 415 for "**Back Inlet Supplies**".

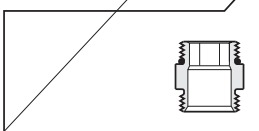
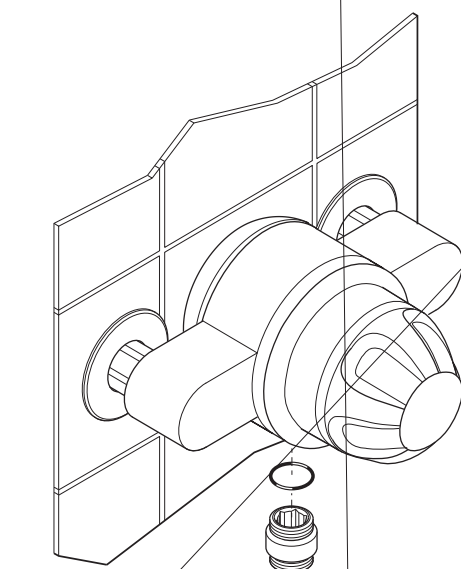

Mira CombiForce 415B Built-in Shower Control

The built-in shower control incorporates an integral wall mounting bracket assembly which can be used to install the shower into a solid, dry-lined, stud partition or dry partition wall structure, shower cubicle or laminated panel. Installers may wish to consider other options such as fabricating rear supports using wooden noggins, however, these methods of fixing are beyond the scope of this guide.

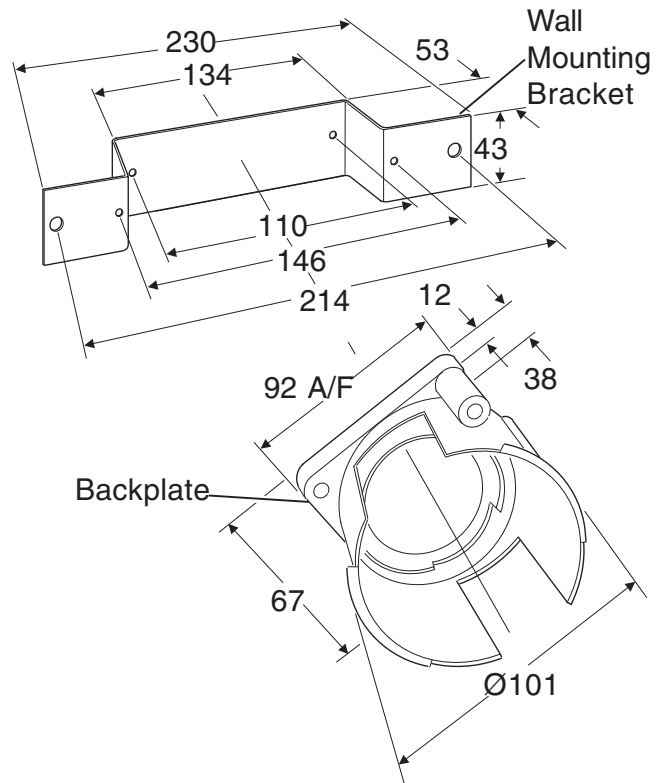

The building-in depth for the integral wall mounting bracket assembly is **58 mm**. The building-in depth for the shower control (to the finished wall surface) is between **64** and **81 mm**. The building-in depth calculation must include the final thickness of plaster and tiles. This dimension determines how much of the control knob will be visible through the concealing plate when the installation is completed.

A building-in shroud is supplied, which protects the shower control during plastering and provides a reference for the building-in depth when chasing out the wall surface.

The built-in shower control has 1/2" BSP male inlets and is supplied with 15 mm compression fittings. The outlet has a 1/2" BSP tapping and supplied with a nipple terminating in a 1/2" BSP male or 15 mm compression fitting.

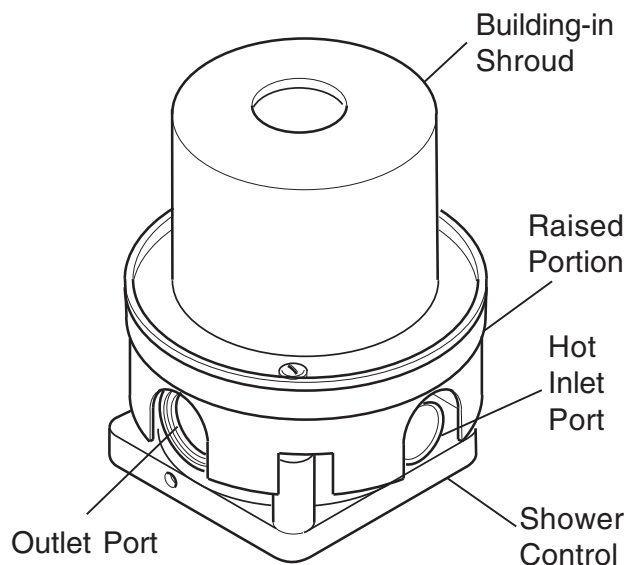

Solid, Dry-lined, Stud Partition or Dry Partition Wall Structures

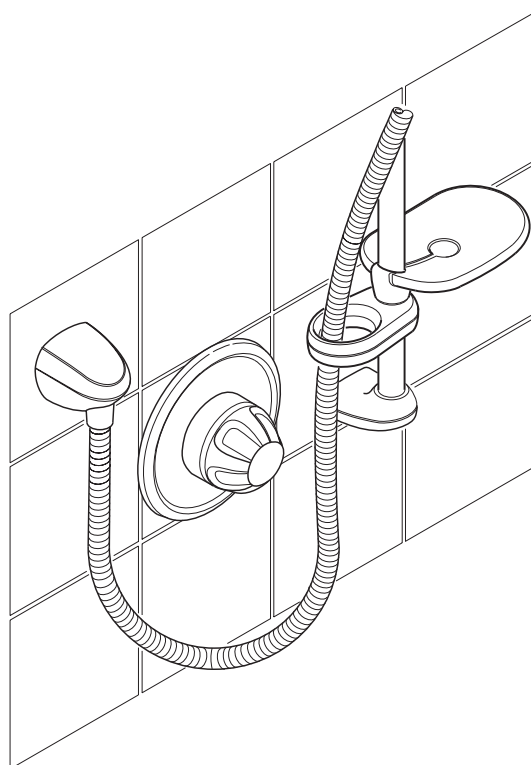
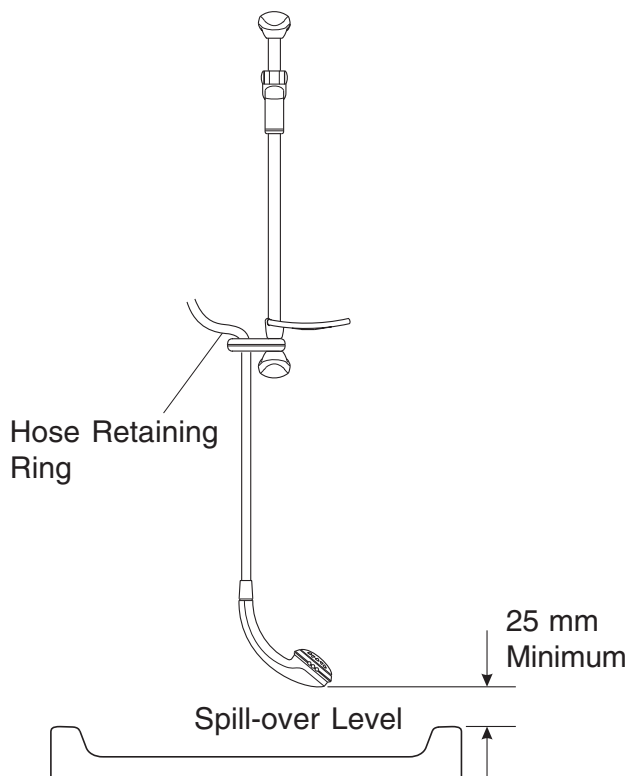

1. Before you decide on the final position of your shower control, please bear in mind the following :

- Decide on a suitable position for the shower control. The position of the shower control and the shower fittings must provide a minimum gap of **25 mm** between the spill-over level of the shower tray/bath and the handset. This is to prevent backsiphonage.
- Determine whether the hot or cold water services will be connected to the shower control from the top (falling) or from the bottom (rising).

2. Remove the plastic building-in shroud. The two M5 x 50 mm building-in shroud retaining screws should be screwed temporarily into the base of the shower control for use later.

3. Familiarise yourself with the hot and cold water inlet ports and outlet port. They can be identified as follows:

The Mira CombiForce 415B is supplied with inlet connections **hot left, cold right** and **top outlet** as standard.

To change the position of the outlet refer to "**Reversed Outlet Connection**": **instructions 1. to 8. inclusive**.

4. Determine the route for the incoming hot and cold water supply pipework. The outlet pipework to a flexible shower fitting is best positioned to emerge above and to one side of the shower control to allow the flexible hose to drape around the underside of the shower preventing the hose from interfering with the knob (refer to diagram).

5. Mark the wall surface for an opening measuring approximately **245 mm** wide and **125 mm** high.

Mark the route of the incoming and outgoing pipework services.

Using the building-in shroud as a guide, remove the plaster and brickwork/dry lining to the required depth of concealment.

Note! The depth of concealment must be such that the final wall surface (e.g. plaster and tiles etc.) finishes on the raised portion of the plastic building-in shroud.

6. Mark the final position on the wall of the two larger outer diameter fixing holes in the flanges of the wall mounting bracket. This bracket must be fixed at 45°.
7. Drill and suitably plug the two marked fixing holes.
8. **Thoroughly flush the incoming hot and cold water supply pipes before connecting the shower control.**
9. Fix the shower control to the wall mounting bracket using the two M4 x 16 mm screws provided.

10. Install the shower control aligning the two flange holes of the wall mounting bracket with the two fixing holes.

Secure the shower control with the two No. 8 x 1 1/4" fixing screws supplied.

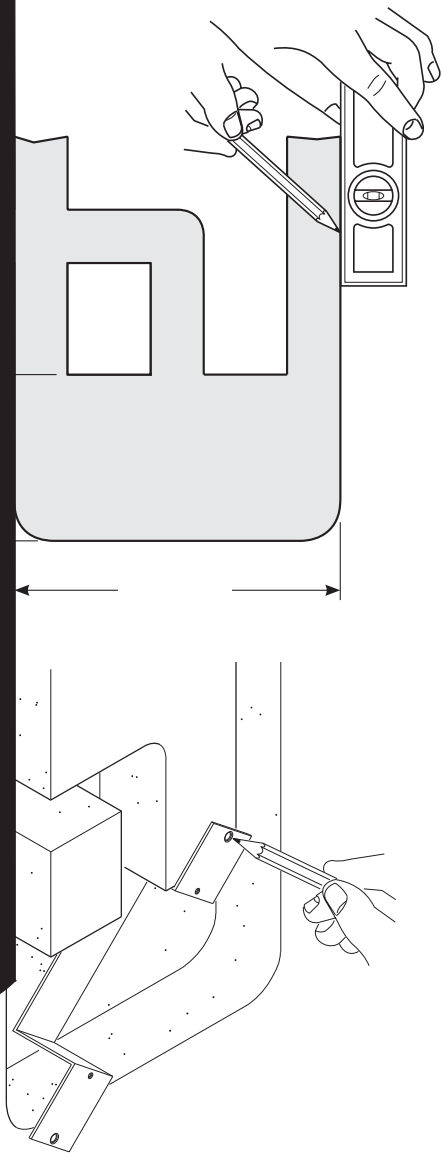

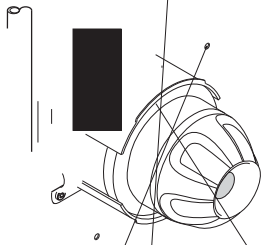

14. Plaster and tile up to the tapered sides of the plastic building-in shroud and, when set remove the shroud. The two M5 shroud retaining screws should be screwed temporarily into the base of the shower control for use later.
15. Push the control knob cap on to the shower control knob.

16. Fit the foam seal over the reverse side of the circular mounting bracket.

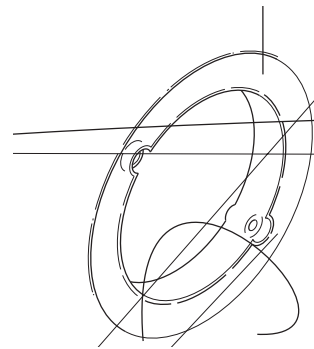

17. Fix the circular mounting bracket to the shower control body using the two M5 x 50 mm screws used to retain the plastic building-in shroud.

Note! The bracket has been designed with semicircular knock outs which may need to be relieved to accommodate the supply pipework under minimum building-in depth conditions.

18. Push the concealing plate firmly over the circular mounting bracket until it locates on the four clips.
19. This completes the installation of the **Mira CombiForce 415B** for installation into “**Solid, Dry-lined, Stud Partition or Dry Partition Wall Structures**”.

Shower Cubicle or Laminated Panel

The built-in shower control incorporates an integral wall mounting bracket assembly which can be used to install the shower into the front or back face of a shower cubicle or laminated panel.

Installation on to the Front Face of a Shower Cubicle or Laminated Panel

Depending on the structure of the shower cubicle or laminated panel it may be possible to conceal the flanges of the integral wall mounting bracket assembly into the front face of the wall surface then cover over the fixings with plaster and tiles. The building-in depth for the integral wall mounting bracket assembly is **58 mm**. The thickness of plaster and tiles which conceal the integral wall mounting bracket assembly flanges must be between **6 and 23 mm**.

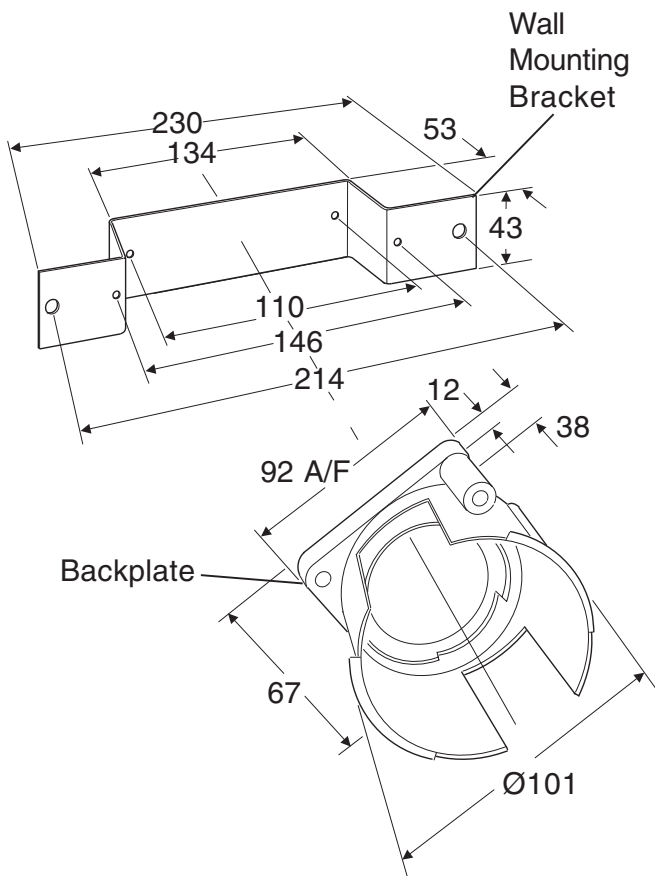

1. Follow the shower control installation procedure as for “**Solid, Dry-lined, Stud partition or Dry Partition Wall Structures**”: instructions 1. to 4. inclusive.
2. Cut a circular hole in the panel measuring **145 mm** in diameter.
3. Follow the shower control installation procedure as for “**Solid, Dry-lined, Stud Partition or Dry Partition Wall Structures**”: instructions 6. to 18. inclusive to complete the installation.

Installation on to the Back Face of a Shower Cubicle or Laminated Panel

The building-in depth for the integral wall mounting bracket assembly is **58 mm**. The integral wall mounting bracket assembly can be used to install the shower control into a shower cubicle or laminated panel of between **4** and **21 mm**. The building-in depth calculation must include the final thickness of plaster and tiles.

1. Follow the shower control installation procedure as for “**Solid, Dry-lined, Stud Partition or Dry Partition Wall Structures**”: instructions **1.** to **4.** inclusive.
2. Cut a circular hole in the panel measuring **124 mm** in diameter.
3. Using the wall mounting bracket as a template, mark the position of the two smaller diameter fixing holes on the flanges of the bracket. These should be at an angle of 45° .
4. Drill the two fixing holes.
5. Fix the shower control to the wall mounting bracket using the two M4 x 16 mm screws provided.
6. Feed the shower control through the opening in the panel and fix to the panel with the two M4 x 30 mm fixing screws.
7. Follow the shower control installation procedure as for “**Solid, Dry-lined, Stud Partition or Dry Partition Wall Structures**”: instructions **11.** to **18.** inclusive to complete the installation.

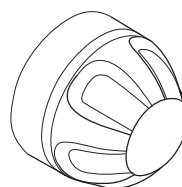



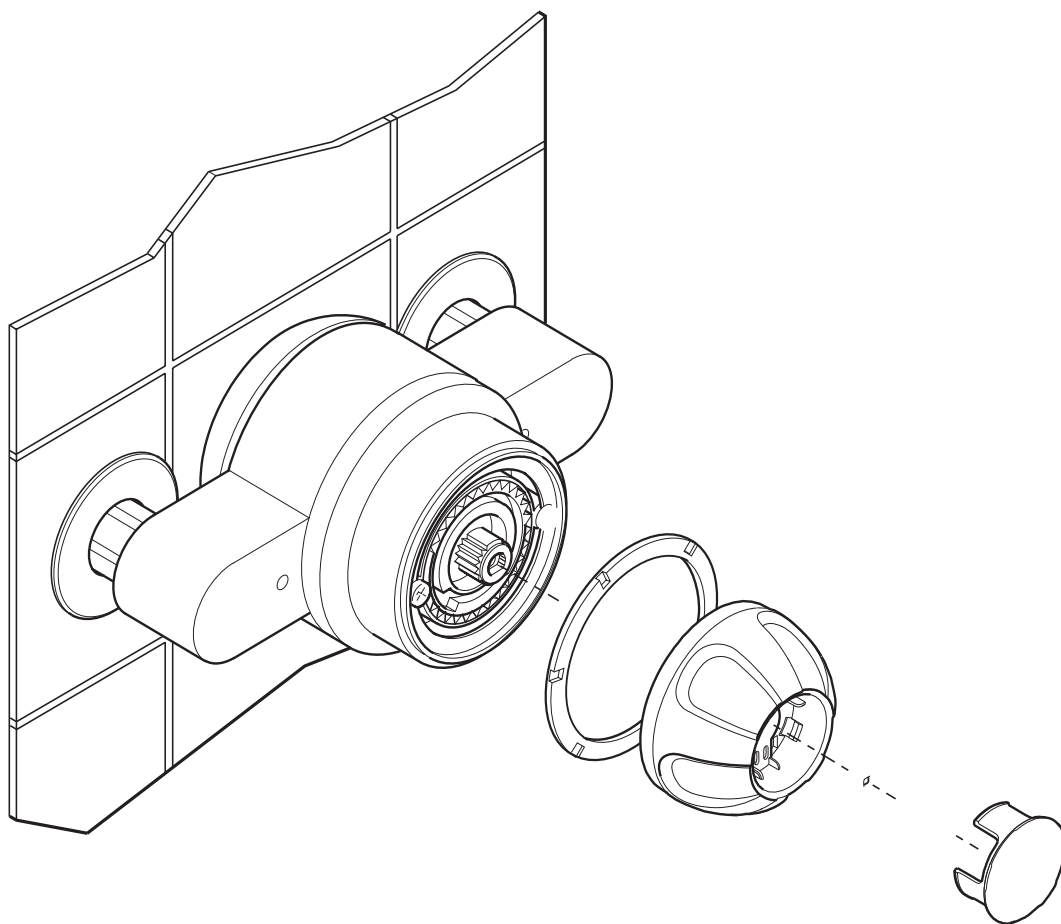

All heater appliances **must have a fully modulating heat output for the domestic hot water**, to provide a constant temperature of hot water to the Mira CombiForce 415 shower control.

Multipoint Gas Water Heaters

These notes are based on a heater with an effective output power of 23.5 kW. Heaters with higher or lower effective output powers will proportionally affect the following information.

The Mira CombiForce 415 range does not compensate for water temperature changes.

1. Use the heater appliance on a “high” or “winter” setting only.
2. A minimum maintained water **supply** pressure of 1.5 bar is required to the water heater. This allows for a 0.5 bar pressure loss in the heater and ensures the maintained inlet pressure at the shower is above 1 bar.
3. The maintained water supply pressure should not exceed 5 bar. A pressure reducing valve will be needed for pressures over 5 bar to improve the system operation. It should be installed to reduce both the cold feed pressure to the heater and the cold feed pressure to the Mira CombiForce 415 to approximately 3.5 bar.

Additional benefits may be obtained by fitting the pressure reducing valve after the premises internal stop valve, drain valve and if fitted, outside tap. The valve should be correctly sized for the duty.

4. If the minimum modulating output of the heater appliance exceeds 14 kW with a reducing hot flow rate, then the maintained minimum supply pressure will need to be increased. This is to keep the flow rate through the heater sufficiently high in order to ensure that the gas flame stays ignited. An extinguished flame will produce a cold shower after a short period of time.

Combination Boilers

1. This information is based on a heater appliance fitted with an internal flow regulator rated at 10 l/min hot water.
2. Use the heater appliance on a “high” or “winter” setting only.
3. Should it not be possible to get a hot enough shower it may be necessary to fit a 9 l/min flow regulator (available from Kohler Mira Customer Services) between the shower control and hose to further reduce the flow. The “top hat” regulator should fit into the hose recess such that the black ‘O’ seal is visible before attaching the hose to the shower control.
4. A minimum maintained water **supply** pressure of 1.5 bar is required. This allows for a 0.5 bar pressure loss in the heater.

5. The maintained water supply pressure should not exceed 5 bar. A pressure reducing valve will be needed for pressures over 5 bar to improve the system operation. It should be installed to reduce both the cold feed pressure to the heater appliance and the cold feed pressure to the Mira CombiForce 415 to approximately 3.5 bar.

Additional benefits may be obtained by fitting the water pressure reducing valve after the premises internal stop valve, drain valve and if fitted, outside tap. The valve should be correctly sized for the duty.

6. The minimum maintained water supply pressure will need to be raised if the minimum heater output power is greater than 7.5 kW on a reducing flow with a hot temperature of 62.5°C.

Adjustable Maximum Temperature Setting

Mira CombiForce 415 shower controls are fully performance tested. The adjustable maximum temperature (maximum angular movement prior to override) has been preset under ideal installation conditions at the factory. Site conditions and personal preference may dictate that the maximum temperature needs to be reset.

To reset the adjustable maximum temperature stop ensure that an adequate supply of hot water is available in excess of that required from the shower control. Turn the control knob fully anticlockwise. Check the temperature at the discharge point (allow hot water to reach the shower). If incorrect, adjust the temperature as follows:

1. Turn the control knob anticlockwise until the desired maximum temperature is achieved. It may be necessary to press the override button and continue to rotate anticlockwise, past the preset maximum temperature setting. Note the final position of the button, e.g. 11 O'clock.
2. Turn the control knob fully off.
3. Remove the concealing cap.
4. Remove the control knob retaining screw/plastic temperature override stop and pull off the control knob.
5. Locate the adjustable temperature stop (identified by a part number and a "MAX °C" symbol or a "MAX °C" symbol and component indentations).

Note! Ensure that the original face identified, is uppermost after adjustment.

6. With reference to the diagrams, carefully remove the adjustable temperature stop. Reposition the stop so that the "MAX °C" symbol is aligned with the noted button position, e.g. 11 O'clock.
7. To check the desired maximum temperature setting has been correctly set, refit the hub and control knob, turn fully anticlockwise and check the temperature of the water at the outlet. If still incorrect:

To **increase** the temperature, reposition the stop one serration **anticlockwise**.

To **decrease** the temperature, reposition the stop one serration **clockwise**.

Repeat the check as necessary.

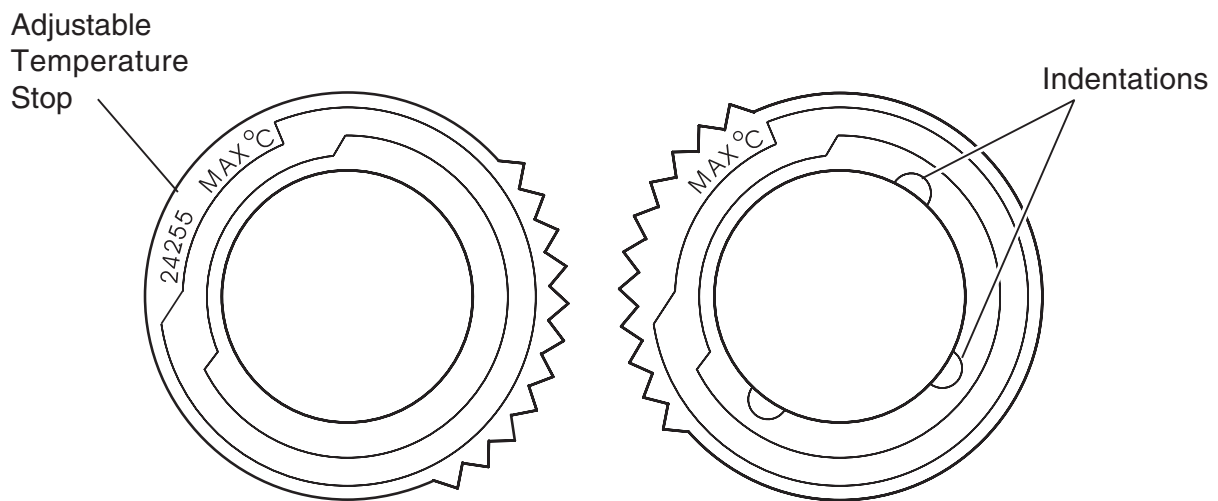
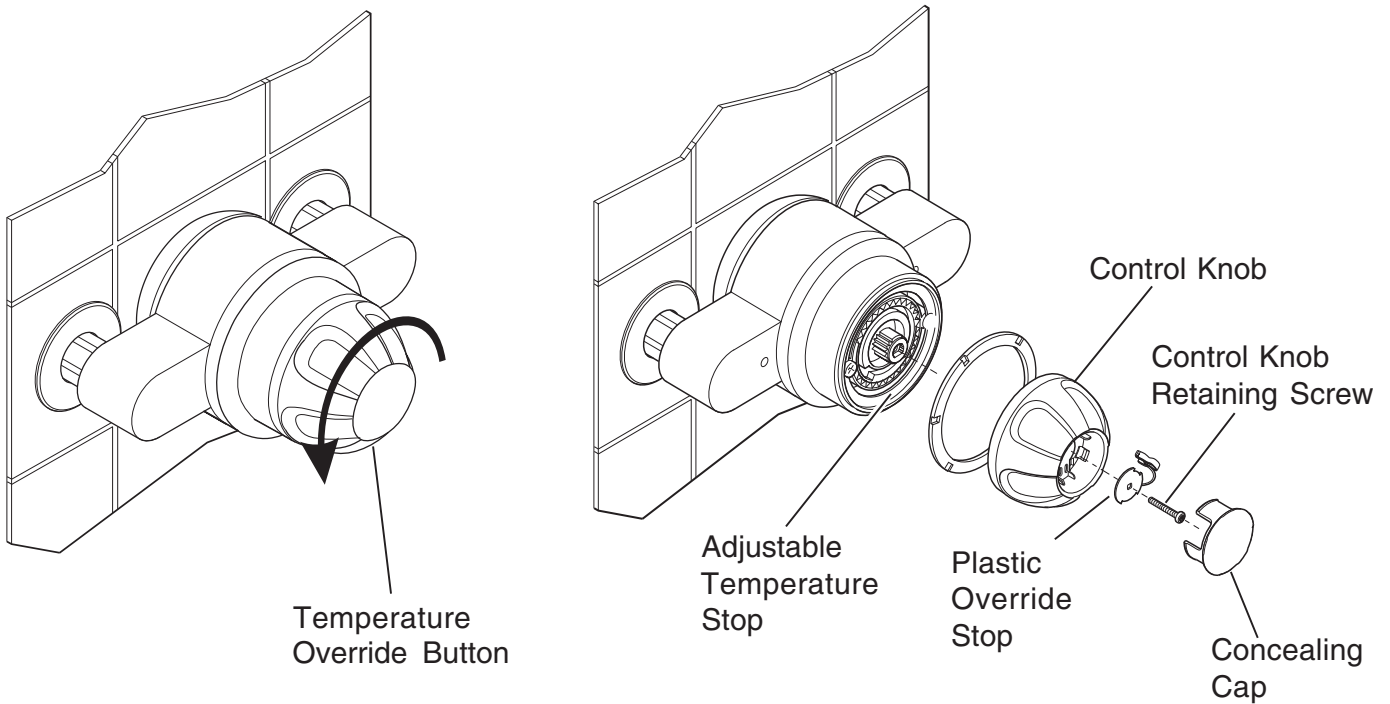

8. Refit the control knob (with the override button at the bottom), control knob retaining screw/plastic override stop and concealing cap. Please ensure the plastic override stop is correctly seated.

Note! Do not overtighten the control knob retaining screw. Internal components may be damaged if the screw is overtightened.

9. This completes the procedure for **Commissioning: "Adjustable Maximum Temperature Setting"**.

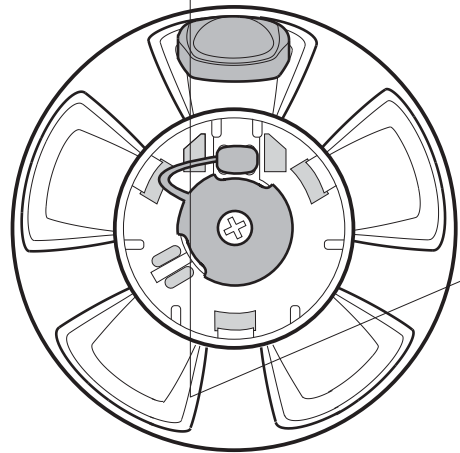
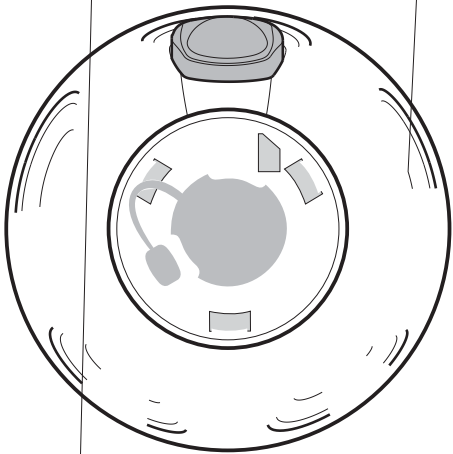

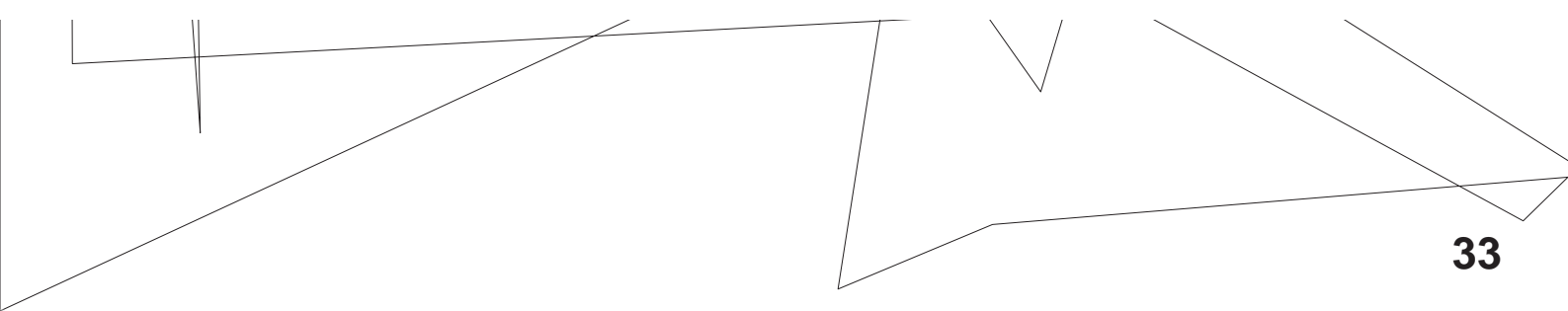
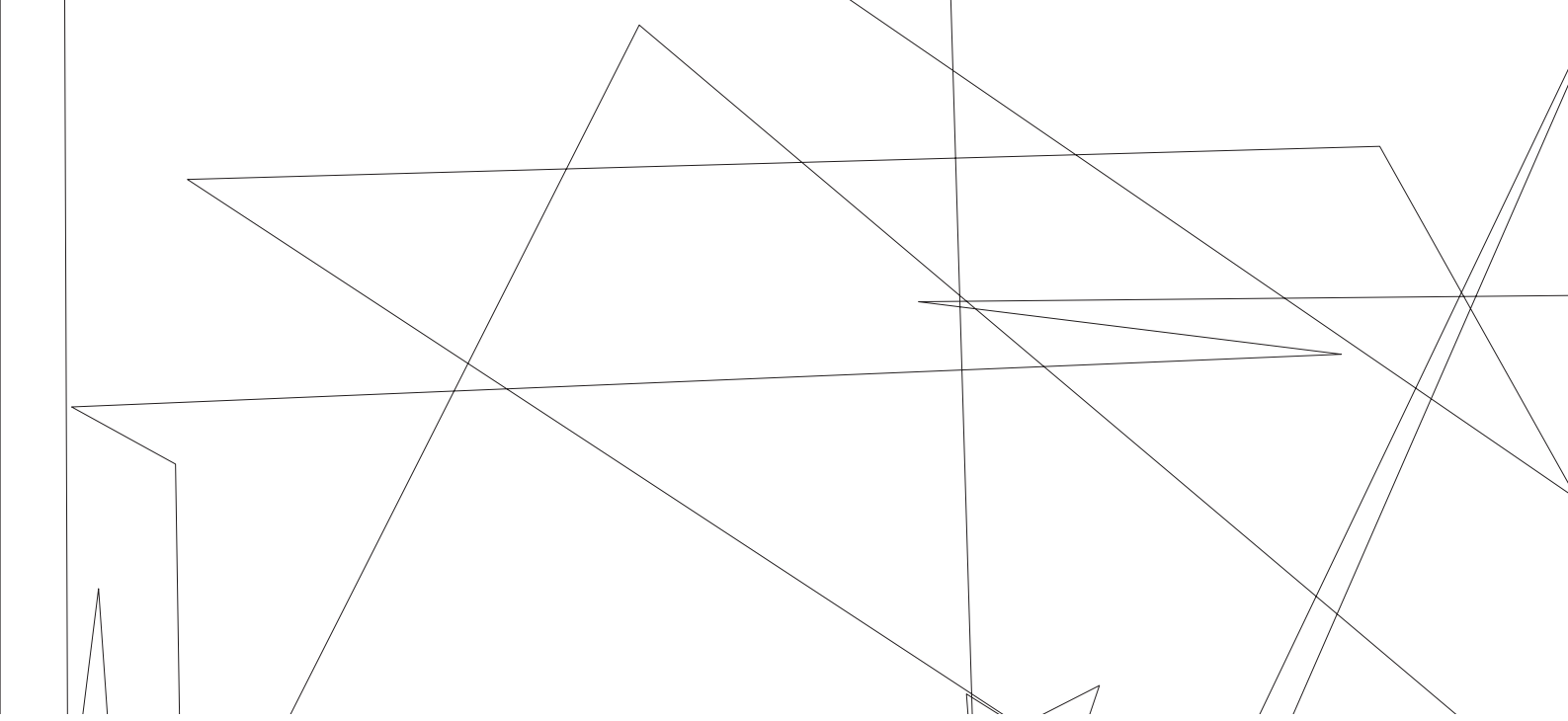

How the pressure balancing principle operates

Mira CombiForce 415 pressure balanced shower controls automatically adjust for variations in **inlet pressures**. This will maintain a constant outlet temperature provided the **inlet water temperatures** remain stable.

The Mira CombiForce 415 is **not** a thermostatic shower control and does not sense supply temperature variations. Therefore, inlet water temperatures especially the hot, must remain relatively constant.

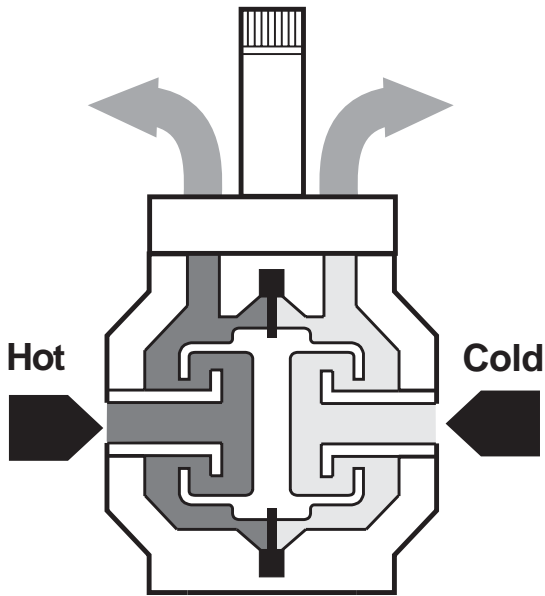

Equal Hot and Cold Pressure
The diaphragm is in the centre.

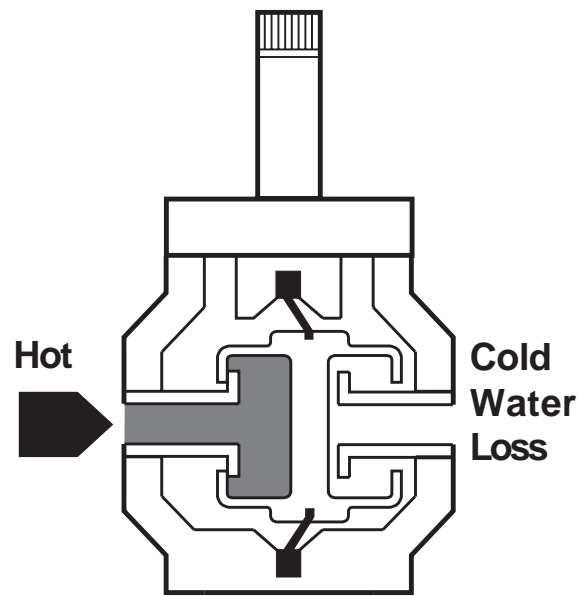

Cold Water Pressure Loss
Diaphragm moves to close hot inlet.

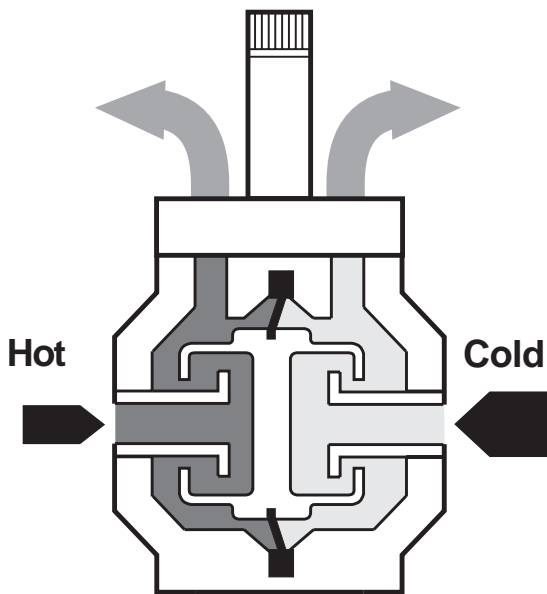

Low Hot and High Cold Pressure
Diaphragm deflects towards hot inlet and restricts cold entry.

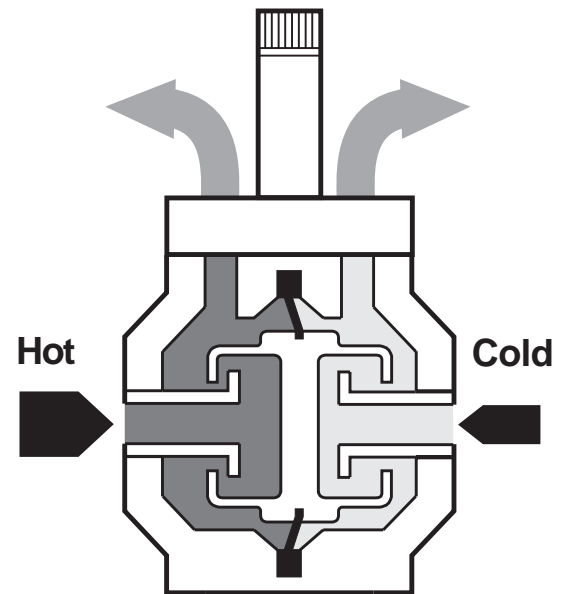

High Hot and Low Cold Pressure
Diaphragm deflects towards cold inlet and restricts hot entry.

Customer Fault Diagnosis

The trouble shooting information tabled below gives details on what you can do as a user should you encounter difficulties whilst operating the shower.

Note! Should these remedies prove to be unsuccessful in solving your problem, contact your installer for further advice.

Key for applicability column

A - Instantaneous gas heated showers.

B - Unvented mains pressure showers.

C - Mains pressurised, instantaneous hot water, heated from thermal store showers.

Malfunction	Cause	Remedy	A	B	C
Shower insufficiently hot.	(a) Maximum temperature incorrectly set.	Reset adjustable maximum temperature.	✓	✓	✓
	(b) Heater not set on maximum hot.	Consult heater instructions or contact a CORGI registered installer.	✓		
	(c) Flow rate still too high.	Fit 9 l/min flow regulator between shower control and hose.		✓	✓
Wide temperature fluctuations from shower when no other draw-off is being made.	(a) Insufficient flow rate causing the heater to cycle on and off.	Check and clean inlet strainers.	✓		
	(b) Insufficient water pressure causing the heater to cycle on and off.	Contact your local water supplier or a CORGI registered installer.	✓		
	(c) Heater not fully modulating.	Contact a CORGI registered installer. See Installation Requirements .	✓		
	(d) See also “ Shower insufficiently hot ”.		✓		

Malfunction	Cause	Remedy	A	B	C
Shower pattern collapses when another hot tap is turned on.	(a) The heater is not capable of supplying several outlets at the same time.	Reduce the simultaneous demand.	✓		✓
	(b) Inlet strainer blocked.	Check and clean inlet strainers	✓	✓	✓
Shower pattern collapses when another cold tap is turned on.	(a) Property water supply pipe partially blocked or undersized.	Contact the local water supplier or your installer.	✓	✓	✓
	(b) Property stop or servicing valve not fully open.	Open valve.	✓	✓	✓
	(c) Insufficient mains cold water pressure.	Contact the local water supplier or your installer.	✓	✓	✓
	(d) Inlet strainer blocked.	Check and clean inlet strainers.	✓	✓	✓
Shower control operating sequence is "off, hot, cool".	Hot and cold water supplies have been connected in reverse.	Refer to the section Installation: "Reversed Inlet Supplies" .	✓	✓	✓
Shower insufficiently hot without pressing red button and rotating further.	Adjustable maximum temperature incorrectly set.	Refer to the section Commissioning: "Adjustable Maximum Temperature Setting" .	✓	✓	✓
Shower control "drums" whilst in use .	(a) Inlet strainer blocked creating an excessive imbalance in inlet pressures.	Check and clean inlet strainers.	✓	✓	✓
	(b) Supply pressure in excess of 5 bar maintained.	Contact your installer.	✓	✓	✓
Shower control "thumps" when another tap is suddenly turned off.	Inlet check valve faulty.	(a) Remove cartridge and if possible clear check valve obstruction.	✓	✓	✓
		(b) Renew cartridge.	✓	✓	✓

Malfunction	Cause	Remedy	A	B	C
Shower force too strong.	High pressure supplies.	Fit 9 l/m flow regulator.		✓	✓
No hot water available	(a) Heater appliance not igniting due to insufficient mains pressure.	Contact the local water supplier or a CORGI registered installer.	✓		
	(b) Heater appliance not igniting due to appliance fault.	Contact a CORGI registered installer.	✓		
	(c) Product hot or cold isolating valve not fully open.	Open valve.	✓	✓	✓
	(d) Hot water run out.	Wait until reheated.		✓	✓
	(e) Inlet strainer blocked.	Check and clean inlet strainers.	✓	✓	✓
Shower starts warm and then runs cool.	(a) Insufficient flow rate.	Refer to “ Wide temperature fluctuations ”.	✓		
	(b) Hot water supply temperature dropped.	Wait for hot water to reheat.		✓	✓
Shower control cannot be shut off.	(a) Pipework not flushed before connecting shower control. (Internal ‘O’ seals damaged).	Renew cartridge. Refer to the section Maintenance: “Cartridge Renewal” .	✓	✓	✓
	(b) Cartridge or inlet strainer ‘O’ seals damaged.	Renew ‘O’ seals with Service Pack.	✓	✓	✓
No flow or low flow from shower head.	(a) Supply stop valve turned down or off.	Open valve.	✓	✓	✓
	(b) Inlet Strainers blocked.	Clean or renew.	✓	✓	✓
	(c) Hose or handset blocked.	Clear blockage. If necessary renew hose or handset.	✓	✓	✓
	(d) Spray plate blocked.	Remove and clean.	✓	✓	✓

Installer Fault Diagnosis: refer to appliance diagram and customer fault diagnosis

Read the section “**Important Safety Information**” first.

Providing the shower has been correctly installed and is operated in accordance with the instructions contained in this guide, difficulties should not arise. If any maintenance is required then it must be carried out by a competent tradesperson for whom the fault diagnosis chart and maintenance instructions are provided. To work on gas heater appliances an installer **MUST** be CORGI registered. Before replacing any parts ensure that the underlying cause of the malfunction has been resolved.

Key for applicability column

A - Instantaneous gas heated showers.

B - Unvented mains pressure showers.

C - Mains pressurised, instantaneous hot water, heated from thermal store showers.

Malfunction	Cause	Remedy	A	B	C
Shower insufficiently hot.	(a) Maximum temperature incorrectly set.	Reset adjustable maximum temperature.	✓	✓	✓
	(b) Heater not set on maximum hot.	Consult heater instructions for further instructions.	✓		
	(c) Flow rate still too high.	Fit 9 l/min flow regulator between shower control and hose.		✓	✓
Wide temperature fluctuations from shower when no other draw-off is being made.	(a) Insufficient flow rate causing the heater to cycle on and off.	Check and clean inlet strainers.	✓		
	(b) Insufficient water pressure causing the heater to cycle on and off.	Increase supply pipe size to premises.	✓		
	(c) Heater not fully modulating.	Refer to Installation Requirements .	✓		
	(d) See also “ Shower insufficiently hot ”.		✓		

Malfunction	Cause	Remedy			
Shower pattern collapses when another hot tap is turned on.	(a) The heater is not capable of supplying several outlets at the same time.	Reduce the simultaneous demand.	✓		✓
Shower pattern collapses when another cold tap is turned on.	(a) Property water supply pipe partially blocked or undersized. (b) Property stop or servicing valve not fully open. (c) Insufficient mains cold water pressure.	Contact the local water supplier or increase supply pipe size to premises. Contact the local water supplier or increase supply pipe size to premises.	✓	✓	✓
Shower control operating sequence is "off, hot, cool". Shower insufficiently hot without pressing red button and rotating further.	Hot and cold water supplies have been connected in reverse. Adjustable maximum temperature incorrectly set.	Refer to the section Installation: "Reversed 2085 T82[0.0001 Tc-0.065 Tw(Conta			
Shower control "drums" whilst in use.	(a) Inlet strainer blocked creating an excessive imbalance in inlet pressures.				
Shower control "thumps" when another tap is suddenly turned off.	Inlet check valve faulty.				

Malfunction	Cause	Remedy	A	B	C
Shower force too strong.	High pressure supplies.	Fit 9 l/m flow regulator.		✓	✓
No hot water available	(a) Heater appliance not igniting due to insufficient mains pressure.	Contact the local water supplier or increase supply pipe size to premises.	✓		
	(b) Heater appliance not igniting due to appliance fault.	Refer to heater appliance instructions.	✓		
	(c) Product hot or cold isolating valve not fully open.	Open valve.	✓	✓	✓
	(d) Hot water run out.	Wait until reheated.		✓	✓
	(e) Inlet strainer blocked.	Check and clean inlet strainers.	✓	✓	✓
Shower starts warm and then runs cool.	(a) Insufficient flow rate.	Refer to “ Wide temperature fluctuations ”.	✓		
	(b) Hot water supply temperature dropped.	Wait for hot water to reheat.		✓	✓
Shower control cannot be shut off.	(a) Pipework not flushed before connecting shower control. (Internal ‘O’ seals damaged).	Renew cartridge. Refer to the section Maintenance: “Cartridge Renewal” .	✓	✓	✓
	(b) Cartridge or inlet strainer ‘O’ seals damaged.	Renew ‘O’ seals with Service Pack.	✓	✓	✓
No flow or low flow from shower head.	(a) Supply stop valve turned down or off.	Open valve.	✓	✓	✓
	(b) Inlet Strainers blocked.	Clean or renew.	✓	✓	✓
	(c) Hose or handset blocked.	Clear blockage. If necessary renew hose or handset.	✓	✓	✓
	(d) Spray plate blocked.	Remove and clean.	✓	✓	✓

Mira products are precision engineered to provide satisfactory performance provided they are installed and operated in accordance with the recommendations contained in this guide.

The shower control is designed for the minimum of maintenance in normal domestic use. If a malfunction occurs then this will probably necessitate a complete cartridge replacement.

Important! The cartridge contains no internally serviceable parts.

When installed in very hard water areas (above 200 p.p.m. temporary hardness) your installer may advise the installation of a water treatment device to reduce the effects of limescale formation in the heating appliance and spray plates.

Cleaning

Many household cleaners contain abrasives and chemical substances and should not be used for cleaning plated or plastic fittings. These finishes should be cleaned using a mild washing up detergent or soap solution, and then wiped dry using a soft cloth.

The light golden colour finish is softer than the chrome finish and its abrasive resistance much less. When cleaning or using tools during maintenance extra care must be taken.

Component Interchangeability

Some parts of the latest Mira CombiForce 415 are not interchangeable with earlier models of the Mira range. Spare parts, where different, are available for earlier models. Refer to the specific IO&M guide supplied with your shower or contact customer services for further information (telephone and fax numbers can be found on the back cover of this guide).

Cartridge Renewal

Should the cartridge require renewal then the following procedure should be followed:

Important! Use only silicone based lubricants when reassembling.

1. Turn off the water supplies and open the shower control to relieve the trapped water pressure.
2. Prise off the concealing cap, remove the control knob retaining screw/plastic override stop and the control knob.
3. Remove the two shroud retaining screws and the cover shroud. Note the position of the adjustable temperature stop then remove. Remove the hub.
4. Undo the four cover retaining screws and remove the cover. (A quantity of water will be discharged).

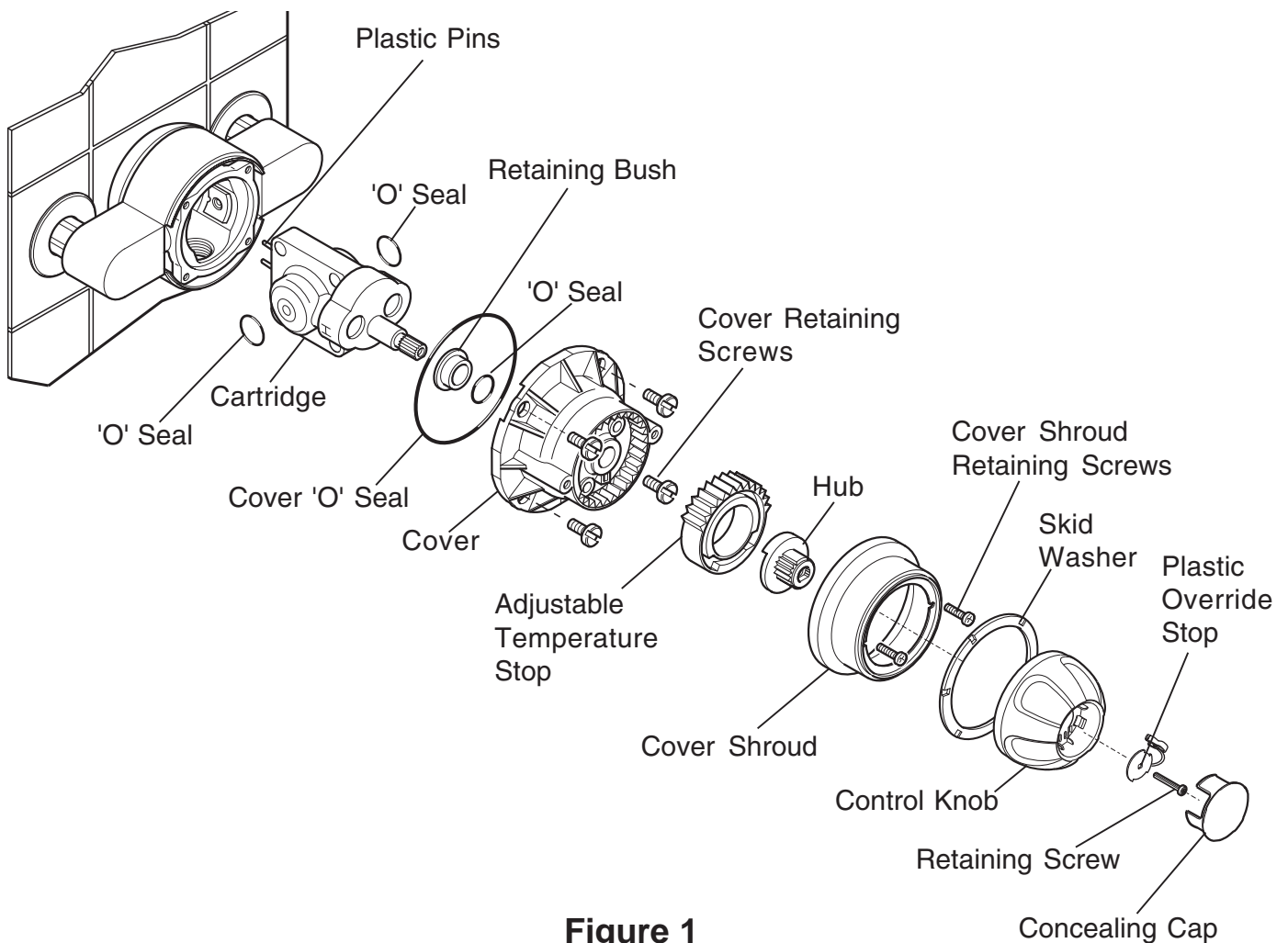

Figure 1

5. Pull the pressure balancing cartridge from the shower control body.
6. Identify which is the hot inlet of the shower control and fit the new cartridge accordingly. The inlets on the new cartridge are marked “H” for Hot, “C” for Cold.
7. Push the cartridge fully into the shower control body. Ensure the two plastic pins locate in the brass body recess.

Make sure that the arrow on the end face of the cartridge points to the letter “C” (refer to Figure 2).

Important! Ensure that the two inlet seals are well-lubricated and correctly located before refitting the cartridge.

8. Ensure that the cover “O” seal is correctly located on the cover.
9. Refit the cover, and secure with the four cover retaining screws. Make sure that the flat on the spindle is lowermost (refer to Figure 2).

Note! There is a one-way cartridge location feature on the cover which ensures the cover is correctly fitted.

10. Push the hub onto the spindle.
11. Turn on the water supplies, and check for any leaks.

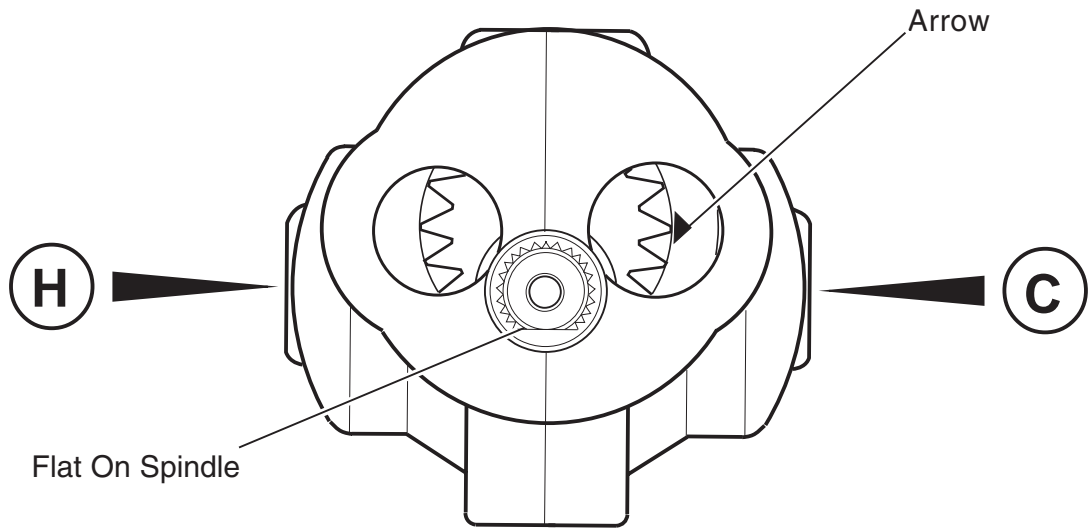

End View Of Cartridge

Figure 2

12. Refit the adjustable temperature stop in its original position.
13. Temporarily fit the control knob (with the override button at the bottom). Rotate the control knob anticlockwise until the desired temperature is achieved. Note the final position of the override button, e.g. 11 O' clock. Rotate the control knob to the "off" position.
14. The maximum temperature will now require resetting following the procedure "**Adjustable Maximum Temperature Setting**" in the section **Commissioning**.

find yourself here

Inlet Strainer Cleaning

Should the inlet strainer units require cleaning or renewal then follow the procedure below:

Important! Use only silicone based lubricants when reassembling.

1. Follow the procedure detailed in “**Cartridge Renewal**”: instructions 1. to 5. to dismantle the shower control.
2. Pull the inlet strainer units from the valve body.
3. Clean the complete strainer unit under running water. Check for damage and renew the whole unit if necessary.
4. Refit the strainer units. The strainer units can only be fitted one way (refer to Figure 4).

Important! Ensure the 'O' seals on the inlet strainers are well-lubricated before refitting.

5. Follow the procedure detailed in “**Cartridge Renewal**”: instructions 7. to 14. to reassemble the shower control.

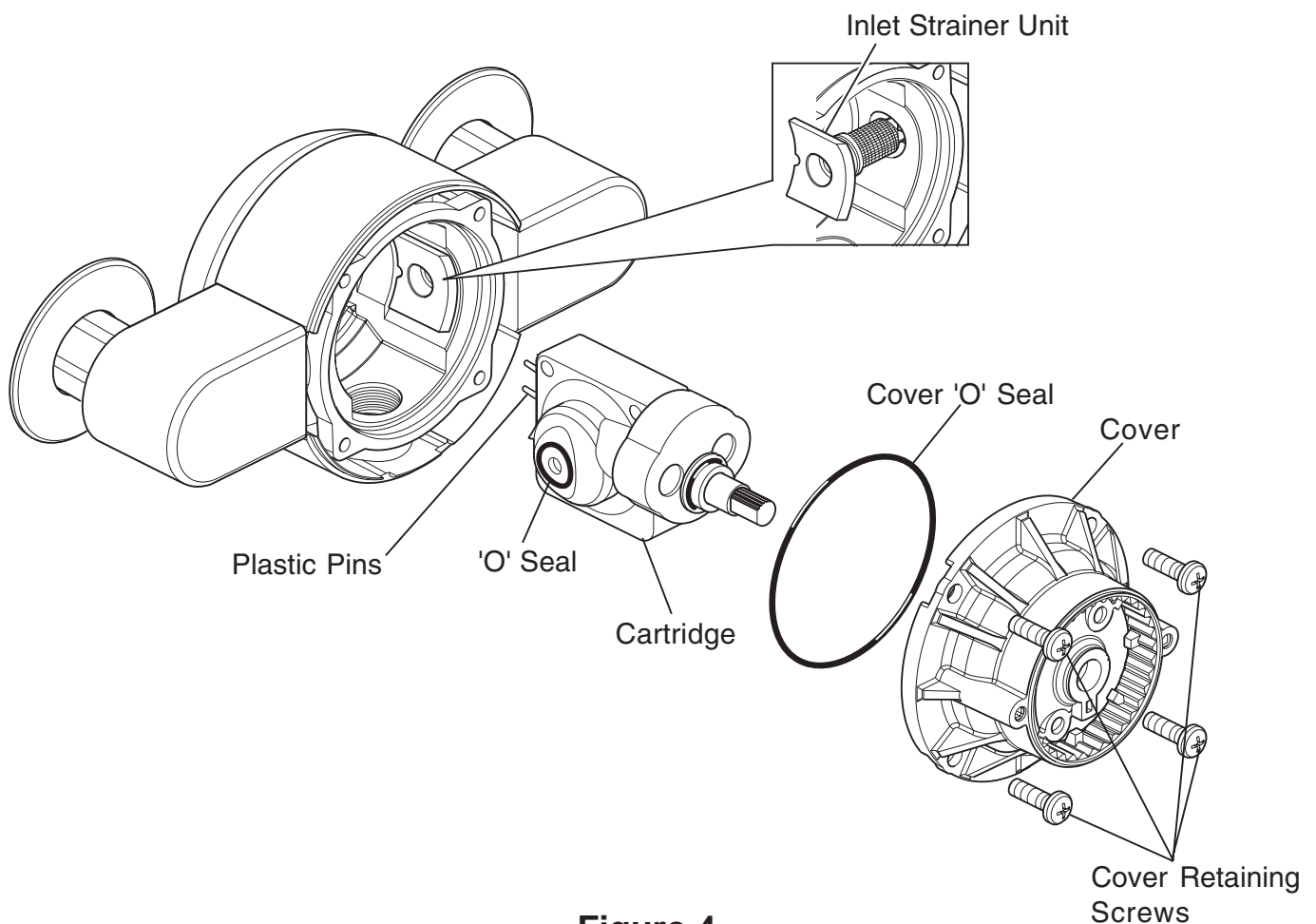
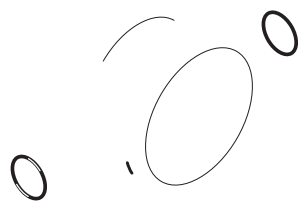

Figure 4

CombiForce 415 Spare Parts List

012.12	Cover
242.55	Adjustable Temperature Stop
280.07	Inlet Compression Fitting - chrome
280.15	Inlet Compression Fitting - light golden
553.35	Outlet Nipple Assy - chrome
553.54	Outlet Nipple Assy - light golden
575.12	2.5mm Hexagon Wrench
617.18	CombiForce 415 Body (including strainers)
617.20	Shroud Pack CombiForce 415 - white
617.21	Shroud Pack CombiForce 415 - chrome
617.22	Control Knob Assembly CombiForce 415 - white
617.23	Control Knob Assembly CombiForce 415 - chrome
617.29	Shroud Pack CombiForce 415 - white/light golden
802.27	Inlet Elbow Assembly - chrome
802.33	Inlet Elbow Assembly - light golden
902.55	Cartridge Assembly
932.25	Hub Pack
936.22	CombiForce 415 Service Pack - components identified 'A'



CombiForce 415B Spare Parts List

012.12	Cover
119.85	Wall Mounting Bracket
242.55	Adjustable Temperature Stop
410.53	Concealing Plate - white
410.54	Concealing Plate - chrome
410.55	Concealing Plate - light golden
555.67	Outlet Nipple
575.12	2.5mm Hexagon Wrench
617.19	CombiForce 415B Body (including strainers)
617.22	Control Knob Assembly - white
617.23	Control Knob Assembly - chrome
807.28	Backplate Assembly - components identified 'B'
902.55	Cartridge Assembly
932.04	Inlet Compression Fitting
932.25	Hub Pack
936.22	CombiForce 415 Service Pack - components identified 'A'
937.59	Screw Pack - components identified 'C'

DCV-H: An outlet double check valve, requiring a minimum inlet supply pressure of 0.5 bar, which has been designed to prevent the backflow or backsiphonage of potentially contaminated water, through shower controls which are fitted with a flexible hose as part of the outlet shower fitting. Available as an optional accessory from your Mira stockist.

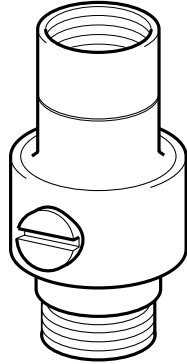

DCV-H Outlet double check valve

9 litre/min Outlet Flow Regulator (Part No. 146.84): Designed to limit the flow rate in high pressure installations. If the maximum obtainable water temperature at the shower outlet is not sufficiently hot, fitting a flow regulator may increase the outlet water temperature and may also reduce the shower force at the outlet (see **Commissioning**). Available from Mira customer services.

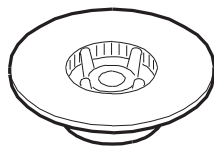

9 litre/minute Flow Regulator

Notes

Customer Service

Guarantee of Quality

Mira Showers guarantee products against any defect of materials or workmanship for one year from the date of purchase (2 years for Mira Select and 3 years for Mira Excel ranges).

To validate the guarantee, please return your completed registration card.

Within the guarantee period we will resolve defects, free of charge, by repairing or replacing parts or modules as we may choose.

To be free of charge, service work must only be undertaken by Mira Showers or our approved agents in Northern Ireland and Republic of Ireland.

Service under this guarantee does not affect the expiry date. The guarantee on any exchanged parts or product ends when the normal product guarantee period expires.

Not covered by this guarantee:

Damage or defects arising from incorrect installation, improper use or lack of maintenance, including build-up of limescale.

Damage or defects if the product is taken apart, repaired or modified by any person not authorised by Mira Showers or our approved agents.

This guarantee is in addition to your statutory and other legal rights.

Before using your shower

Please take the time to read and understand the operating and safety instructions detailed in this manual.

What to do if something goes wrong

If when you first use your shower it doesn't function correctly, first contact your installer to check that installation and commissioning are satisfactory and in accordance with the instructions in this manual. We are on-hand to offer you or your installer any advice you may need.

Should this not resolve the difficulty, simply contact our Customer Services who will give every assistance, and if necessary arrange for our service engineer to visit.

If later the performance of your shower declines, consult this manual to see whether simple home maintenance is required. Please call our Customer Services to talk the difficulty through, request service under guarantee if applicable, or take advantage of our comprehensive After-Sales service.

As part of our quality and training programme calls may be recorded or monitored

After Sales Service

Our Customer Services Team is comprehensively trained to provide every assistance you may need: help and advice, spare parts or a service visit.

Spare Parts

We maintain an extensive stock of spares, and aim to have functional parts available for ten years from the date of final manufacture of the product.

Spares can be purchased from approved stockists or merchants (locations on request) or direct from Customer Services.

Spares direct will normally be despatched within two working days. Payment can be made by Visa or Access at the time of ordering. Should payment by cheque be preferred a pro-forma invoice will be sent.

Note! In the interests of safety, spares requiring exposure to mains voltages can only be sent to competent persons.

Service

Our Service Force is available to provide a quality service at a reasonable cost. You will have the assurance of a Mira trained engineer/agent, genuine Mira spares – and a 12 month guarantee on the repair.

Payment should be made directly to the Service Engineer/Agent, using Visa, Access or a cheque supported by a banker's card.

To contact us:

England, Scotland & Wales

Mira Showers Customer Services

Telephone: 01242 262888
8.30am to 5pm Working days (4.30pm Fri)
8.30 am to 12.30pm Saturday
E-mail: Mira_technical@mirashowers.com
Fax: 01242 282595
By Post: Cromwell Road
Cheltenham
Gloucester GL52 5EP

For Customers in Northern Ireland

Wm H Leech & Son Ltd

Telephone: 028 9044 9257 – Mon to Fri 9 am-5pm
Fax: 028 9044 9234 – 24 hours
Post: Maryland Industrial Estate
Ballygowan Road
Moneyreagh, Co Down
BT23 6BL

For Customers in Republic of Ireland

Modern Plant Ltd

Telephone: Dublin 01 4591344 - Mon to Fri 9am to 5pm
Fax: Dublin 01 4592329 – 24 hours
Post: Otter House
Naas Road
Clondalkin
Dublin 22

Mira Showers

Kohler Mira Ltd
Cromwell Road,
Cheltenham GL52 5EP.

Mira is a registered trade mark.
The company reserves the right to alter product specifications without notice.

www.mirashowers.com



FM 14648

mira
SHOWERS