

***Luxury  
body dryer***

**Installation and  
operating  
instructions**

INSTALLERS PLEASE NOTE THESE INSTRUCTIONS ARE TO BE LEFT WITH THE USER

<b>CONTENTS</b>	<b>Page</b>
Important safety information	1
Introduction	2
Specifications	2
Advice to users	2
Fault finding	3
Key to main components	3
Electrical requirements	4
Siting	6
Fitting the body dryer	8
Electrical connections	10
Replacing the cover	12
Commissioning	13
Operating functions	14
Overheat cut out	15
Cleaning	16
Servicing	16
Spare parts	17
Guarantee, service policy, etc.	rear cover

To check the product suitability for commercial and multiple installations, please contact Triton's specification advisory service before installation.

Telephone: +44 (0) 24 7632 5491

Facsimile: +44 (0) 24 7632 4564

E mail: [technical@triton.plc.uk](mailto:technical@triton.plc.uk)

### PLEASE READ THIS IMPORTANT SAFETY INFORMATION

- ◆ Products manufactured by Triton are safe and without risk provided they are installed, used and maintained in good working order in accordance with our instructions and recommendations.
- ◆ All required safety features have been designed and built into the product for your complete protection.
- ◆ **WARNING: Always isolate electrically the dryer or dryer/shower combination when not in use. This is a safety procedure recommended with all electrical appliances.**
- ◆ The dryer has been designed for use in a bathroom or shower room for the purpose personal body drying and will heat a bathroom rapidly. The dryer should not be used for any other purpose. **This dryer MUST NOT be installed directly above a bath or within a shower cubicle. It MUST be installed in either Zone 3 or outside of the zones.**

#### 1 GENERAL

- 1.1 Isolate the electrical supply before removing the cover.
- 1.2 Read all of these instructions and retain them for later use.
- 1.3 DO NOT take risks with plumbing or electrical equipment.
- 1.4 Isolate electrical supplies BEFORE proceeding with the installation.
- 1.5 Contact Customer Service (*see back page*) if the unit shows a distinct change in performance.
- 1.6 The mesh grill on the air inlet should be regularly inspected for any build up of fluff and cleaned if found.
- 1.7 This product is not suitable for mounting into shower cubicles, steam rooms or steam cubicles (*Zone 3 or beyond*).
- 1.8 To enable future servicing to be carried out on the unit:
  - a) When installed in a loft space the body dryer must be sited in an accessible and safe location.
  - b) A safe means of access must be provided into the loft e.g. fixed loft ladder.
  - c) Ceiling joists in the loft must be adequately boarded to provide safe unobstructed access to and around the body dryer.
  - d) There must be adequate lighting in the loft for servicing purposes.

#### 2 ELECTRICAL

- 2.1 The electrical installation must comply with BS7671 'Requirements for electrical installations' (IEE wiring regulations), Building Regulations or any particular regulations as specified by the local Electrical Supply Company.
- 2.2 The appliance and any associated electric

shower MUST be earthed using the main feed earth wire connections provided in the appliances.

- 2.3 In accordance with 'The Plugs and Sockets, etc (Safety) Regulations 1994', this appliance is intended to be permanently connected to the fixed wiring of the electrical mains system.
- 2.4 Make sure all electrical connections are tight to prevent overheating.
- 2.5 Fuses DO NOT provide personal protection against electric shock.
- 2.6 *To enhance electrical safety* a 30mA or 40mA residual current device (RCD) should be installed in all body dryer/shower circuits. This may be part of a consumer unit or a separate circuit.
- 2.7 Switch off the unit immediately at the pull cord isolation switch if the unit comes into contact with water. DO NOT reconnect until a qualified electrician has checked the unit for safety.
- 2.8 The unit is designed to work in association with an instantaneous electric shower where the circuit protective device (fuse) is 40A or 45A rating. No other electrical equipment i.e. extractor fans or pumps should be connected to the body dryer unit.
- 2.9 Always electrically isolate the dryer or dryer/shower combination at the pull cord isolation switch when not in use. This is a safety procedure recommended with all electrical appliances.
- 2.10 As with all electrical appliances it is recommended to have the body dryer and any associated shower unit installation checked at least every two years by a competent electrician to make sure there is no deterioration due to age and usage.

### INTRODUCTION

This book contains all the necessary fitting and operating instructions for your Triton Luxury Body Dryer. Please read them carefully.

The Body Dryer installation must be carried out by a suitably qualified person and in the sequence of this instruction book.

Care taken during the installation will provide a long, trouble-free life from your body dryer.

The Body Dryer has been designed for use in a bathroom or shower room for the purpose of personal body drying. The dryer should not be used for any other purpose.

**Never install in a shower cubicle or steam room, only Zone 3 or outside of the zones of a bathroom (fig.3).**

### SPECIFICATIONS

#### Electrical

Nominal power rating at 240V	Nominal power rating at 230V
9.0kW – (40A MCB rating)	8.3kW – (40A MCB rating)

Trickle current on OFF mode is 0.04A at 240V (9.6W) but is not isolated.

Minimum cross sectional area of supply cable is 6mm<sup>2</sup>. Derating factors should always be taken into consideration when selecting cable size.

#### Materials

Main unit – 20% Glass filled Polypropylene  
Cover – ABS

#### Dimensions

Width – 335mm, Length – 625mm,  
Height – 175mm

Above ceiling – 140mm

Below ceiling – 70mm (cover)

Weight – 7kg

Packed weight – 10kg

#### Standards and Approvals

Complies with requirements of current British and European safety standards for household and similar electrical appliances.

Complies with requirements of the British Electrotechnical Approvals Board BEAB.

Meets with compliance with European Community Directives CE. EMC

### ADVICE TO USERS

The following points will help you understand how the Body Dryer operates:

**a.** The unit consists of a high powered two speed fan and 2 x 4.5kW heater elements which are fully controllable using the hand-held controller (supplied). Air is drawn in through the filter, passed across the elements and then discharged downwards.

**b.** DO NOT place pressurised aerosol cans in or under the hot air flow. Always electrically isolate the dryer or dryer/shower combination when not in use.

**c.** Temperature sensors are fitted to the unit for your safety. However, the best sensor is you. If you find the airflow or room temperature rises to uncomfortable levels switch off or regulate the flow through use of the controller. Never leave alone those unable to recognise or react to discomfort with the dryer switched on.

For ideal comfort and drying time the ceiling height should be between 2.2m to 2.5m.

The dryer has a 10-minute preset cut off.

**d.** The unit can be connected in combination with an electrical shower rated from 8kW up to 10.5kW. The electrical safety features incorporated in the unit do not allow the Body Dryer to be operated while the shower is on and vice versa.

**e.** The hand-held controller should be kept away from sources of water.

**f.** The LED's incorporated into the cover show the operational status of the Body Dryer or any fault condition. If you suspect the unit to be faulty unqualified attempts to rectify the situation should be limited to isolating and switching on the unit via the pull cord and operation of the hand-held controller (*see commissioning instructions*). All other problems MUST be attended to by a competent electrician or service engineer.

Due to continuous improvement and updating, specification may be altered without prior notice.

Replacement parts can be ordered from Customer Service. See 'spare parts' for details and part numbers.

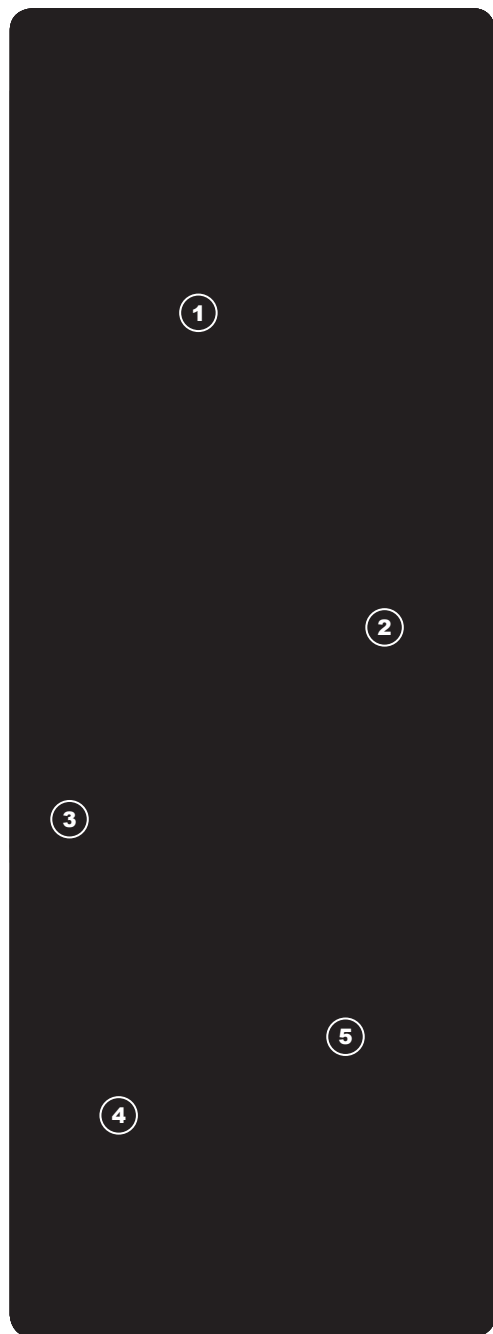

## ELECTRICAL REQUIREMENTS

### WARNING!

**WHEN USED INDEPENDENTLY OR IN TANDEM WITH AN ELECTRIC SHOWER THIS APPLIANCE MUST BE EARTHED (EARTH CONTINUITY MUST BE MAINTAINED).**

The installation, supply cable and circuit protection must conform with BS7671 (IEE wiring regulations) and be sufficient for the amperage required.

The following notes are for guidance only:

- 1 The body dryer must only be connected to a 230 – 240V ac supply (single phase).
  - 2 If an instantaneous electric shower circuit already exists the body dryer may be connected in series with the shower subject to confirmation that the electrical circuit complies with current IEE regulations.
- 2.1** The electrical rating of the body dryer is shown on the rating label within the unit.

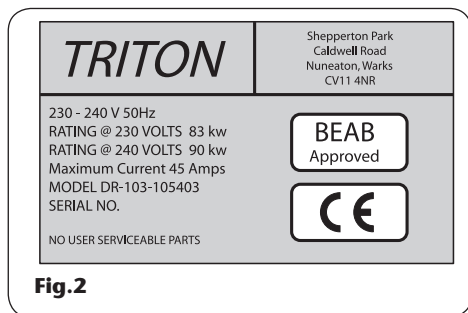

Fig.2

- 3 Before making any electrical connection within the installation make sure that no terminal is live. If in any doubt switch off the whole installation at the mains and remove the correct circuit fuse.
- 4 If the installation is undertaken by anyone who is not registered to issue a Part P electrical certificate then it will be necessary to notify the local Building Control office before installing.

- 5 The body dryer must be connected to its own independent electrical circuit as determined by the IEE regulations but it can share the same supply as an electric shower providing the wiring connections follow that of the wiring schematic shown in the electrical connections section.

The body dryer MUST NOT be connected to a ring main, spur socket outlet, lighting circuit or cooker circuit.

**Note:** Safety features built into the body dryer prevent the unit and any shower fed via the body dryer from operating at the same time.

- 5.1 The electrical supply must be adequate for the maximum loading of the unit and/or any existing shower circuit.
- 6 Check the consumer unit (main fuse box) has a main switch rating of 80A or above and that the fuse way will take the necessary fuse or MCB to provide the maximum electrical load (amps) of the body dryer and shower if applicable.
- 6.1 If the consumer unit has a rating below 80A or there is no spare fuse way then the installation may require a new consumer unit serving the house or just the body dryer/shower.
- 6.2 If you do not have the necessary supply you will need to contact the local electricity company regarding upgrading the incoming supply.
- 7 The earth continuity conductor of the electrical installation must be effectively

Table A

CIRCUIT PROTECTION		
unit rating	MCB	cartridge fuse
8.0kW	40A	35A
8.5kW	40A	45A
9.0kW	40A	45A
9.5kW	40/45A	45A
10.5kW	45A	45A

connected electrically to all exposed metal parts of other appliances and services in the room in which the body dryer and an electric shower is to be installed, to conform to current IEE regulations.

**7.1** All exposed metal parts in the bathroom must be bonded together using a cable of at least 4mm<sup>2</sup> cross sectional area. These parts include but are not limited to metal baths, radiators, water pipes, taps and waste fittings.

**8.** For close circuit protection DO NOT use a rewireable fuse, instead use a suitably rated miniature circuit breaker (MCB) or cartridge fuse (**see table A**).

**8.1** In the further interest of electrical safety a 30mA or 40mA residual current device (RCD) should be installed in wiring for all body dryer installations.

**9** A 45 amp double pole isolating switch with a minimum contact gap of 3mm in both poles must be incorporated in the circuit.

**9.1** This isolating switch must also have a mechanical indicator showing when the switch is in the OFF position and the wiring must be connected to the switch without the use of a plug or socket outlet.

**9.2** The switch must be accessible and clearly identifiable, but out of reach of a person using a fixed bath or shower, except for

1 Tf8 0 3 8 0 0 8w.m(Using )-29(a )-l8lier, reach of 1 Tf8 0Tm@viriafixed )3 397.031 1 Tfnot(using )-29



The dryer has been designed for use in a bathroom or shower room for the purpose of personal body drying and will heat a bathroom. The dryer should not be used for any

Access to electrical connections and the routing and security of electrical cables should always be paramount, particularly the isolation switch (see *Electrical Requirements*).

**Fig.4** shows a typical system layout.

As a minimum, a floor area of 600mm diameter should be allowed directly below the output vent (rectangular nozzle) of the body dryer for the user to stand in (**fig.5**). However, the user will benefit most where the area under the dryer is the largest area possible of clear floor space.

**Note:** The body dryer should not be positioned over a bath or within a shower cabinet.

Use the template (**fig.6**) and cover to determine the best position for the body dryer. Careful observation and measurement both above and below the ceiling will ensure all factors are taken into account before any drilling or cutting takes place.

Always try the body dryer template in a selected location before proceeding further.

**IMPORTANT:** Loft insulation that occupies the space required for the dryer should be removed or rolled back. The unit must be installed on flat surfaces both above and below the ceiling otherwise difficulty may be encountered when fitting the ceiling cowl and subsequent operation of the unit may be impaired.

**Note:** To install the Body Dryer to a concrete ceiling with an additional suspended ceiling or a bathroom with a timber flat roof construction you will need to use an optional fitting kit (not supplied). Contact Triton Customer Service for further details.

Once installed, care should be taken to ensure the immediate area around the body dryer unit within the loft space remains a clear of obstructions and that other items are not placed against the unit or in close proximity.

It is recommended that the electrical feed cables are secured to a convenient joist (**fig.7**).

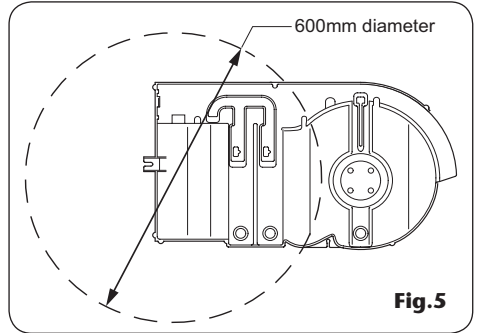

**Fig.5**

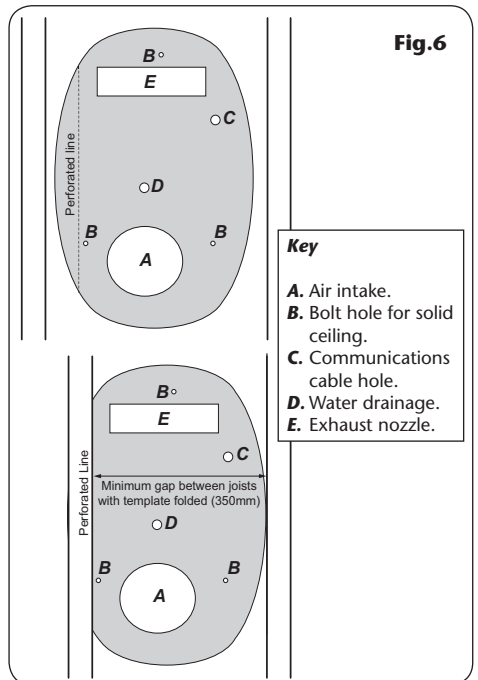

**Fig.6**

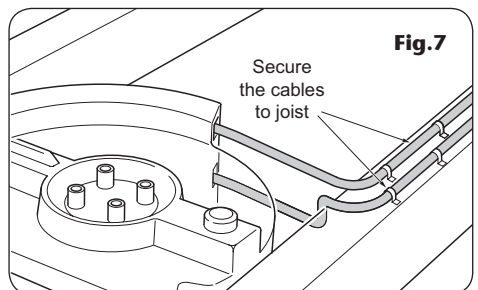

**Fig.7**

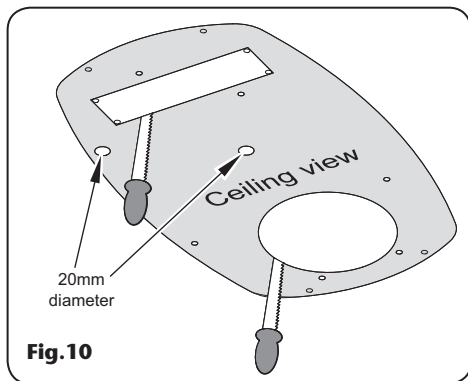
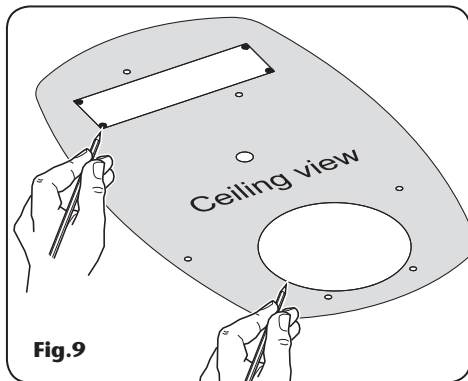
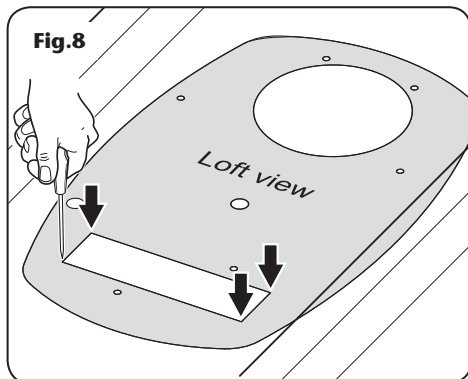

## FITTING OF THE DRYER

Before installation check the parts for any signs of obvious damage.

Read, understand and follow the installation safety guidelines that come with this product.

The dryer has been designed for use in a bathroom or shower room for the purpose of personal body drying. The dryer should NOT be used for any other purpose; see 'Siting'.

### Parts check list

Hand-held controller and battery (3V Lithium 12032)

Main unit

Ceiling cover

Template

Support straps and staples

Ceiling fittings

### Tools required

Electrical test meters

Small bradawl/small screwdriver

Marker pen/pencil and straight edge

Pad saw

Crosshead screwdriver

Flat head screwdriver

Hand-held drill with 8mm drill bit

Protective goggles/glasses and face mask

### Procedure

Use the template and cover to determine the best position for the body dryer. Careful observation and measurement both above and below the ceiling will ensure all factors are taken into account before any marking, drilling or cutting, takes place.

If the template does not fit easily between the roof joists then a section of joist may have to be removed and the remainder supported by cross members attached to the adjacent joists with suitable supports on either side of the unit.

**IMPORTANT:** This task is beyond the scope of this book and should NOT be attempted unless the installer is suitably experienced and has the knowledge and skills to maintain a secure structure.

The minimum distance between joists is 355mm.

**Tip:** Remember, sound advice is to measure twice, cut once.

**Note:** The cut-outs in the template are not symmetrical about the centre of the template. When positioning the template make sure to use the correct aspect.

Place the template supplied in the selected position in the roof space and push a bradawl or thin screwdriver through the plasterboard to mark the four corners of the rectangular cut out, the centre of the round hole and the centres of the two smaller holes (**fig.8**). Remember, you are pushing through plasterboard and the minimum effort required should be used.

From below, line up the template with the holes made in the ceiling and mark the cut outs and cover locating holes with a pen (**fig.9**).

Before making any cuts align the cover to these markings to confirm the chosen position.

Drill the four corners of the rectangular cut out and one point on the inner edge of the large round hole with an 8mm drill bit to allow for a pad saw to be used (**fig.10**). Open out the two smaller holes to 20mm diameter.

When drilling or cutting from below it is recommended that eye protection is used. Waste material should be collected at the highest convenient point since airborne particles can cause respiratory discomfort. A vacuum cleaner nozzle close to the drill bit or pad saw cut can also reduce the overall volume.

**Fig. 15**

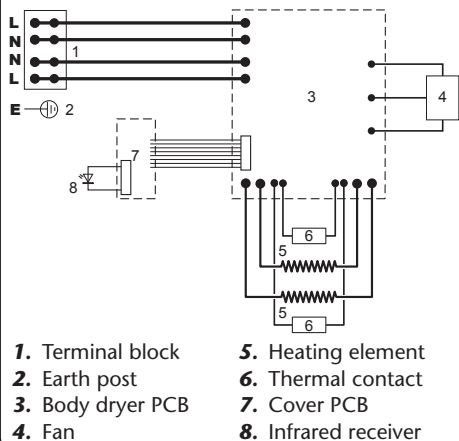

**ELECTRICAL CONNECTIONS**

**SWITCH OFF THE ELECTRICITY SUPPLY AT THE MAINS.**

**Fig. 15** shows a schematic wiring diagram.

**Fig. 16** shows a connection diagram which must be followed without deviation. This is particularly important where a body dryer and shower combination are using the same feed cable.

A built-in safety feature of the body dryer prevents both devices from operating at the same time and overloading the electrical wiring.

**Note:** The terminal block that connects the shower cable to the dryer is LIVE whenever the dryer is not electrically isolated.

- Live conductor (Brown or Red) to terminal marked **L**
- Neutral conductor (Blue or Black) to terminal marked **N**
- Earth conductor to terminal marked **E** (⊥)

**Fig. 16**

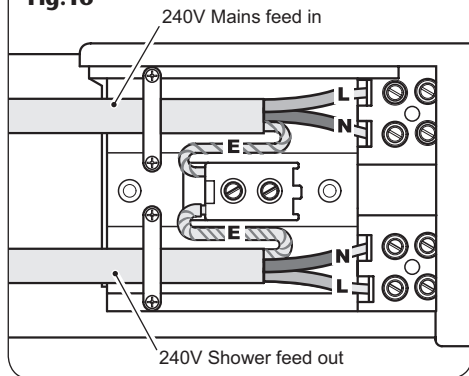

The mains cable should be firmly secured using the clamps provided.

The earth wire should be physically longer than the live and neutral wires.

**IMPORTANT:** Where a shower is involved earth continuity is essential to provide a safe operating environment.

Fully tighten the terminal block screws and make sure no cable insulation is trapped under the screws. Loose connections can result in the cable overheating.

**Fig. 17**

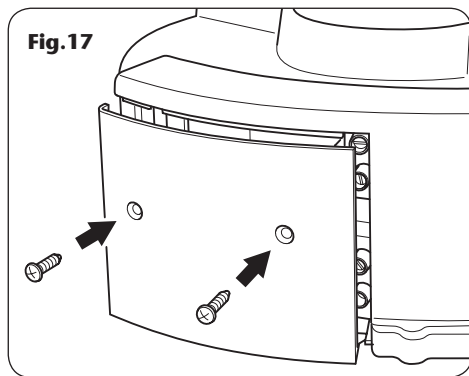

**Notes**

Good wiring practice advises that:

The supply cable earth conductor must be sleeved.

The outer sheath of the supply cable must be stripped back to the minimum.

The supply cable must be secured either by routing through conduit or in trunking or by embedding in the wall, in accordance with current IEE regulations.

DO NOT switch on the electricity supply until all safety covers have been correctly fitted.

Replace the wiring safety cover (**fig.17**).

### **Connecting the body dryer to a shower**

Where a shower is to share the same electrical supply the wiring should be routed as shown in **fig.18**. The connectivity at the body dryer is as shown in **fig.15** and adjacent to the connecting blocks on the body dryer.

Always be aware that the electrical supply and electrical safety MUST meet the requirement for the larger of the two loads.

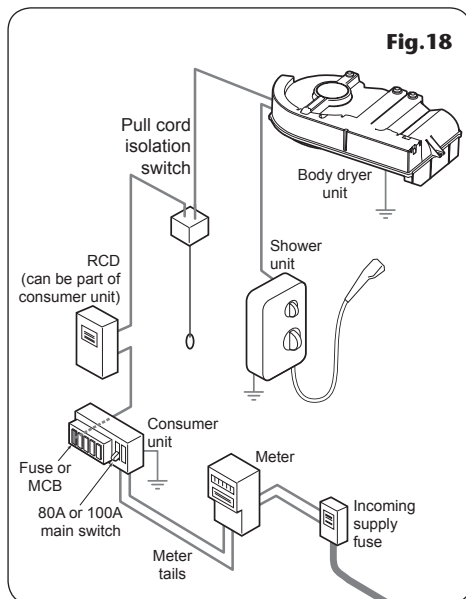

### REPLACING THE COVER

Place the cover up to unit and align with the outlet nozzle. Mark the position of the four cover screw holes (**fig.18**). Remove the cover and screw the four plasterboard rawl plugs into the positions marked on the ceiling.

Connect up the multiway cable to the PCB unit within the ceiling cover (**fig.19**). Secure the multiway cable in the strain relief tabs located in the cover and then secure the cover to the ceiling using the screws supplied.

The unit is now ready for commissioning.

Retain the packaging should the unit need to be returned under warranty; otherwise dispose of in an environmentally friendly way.

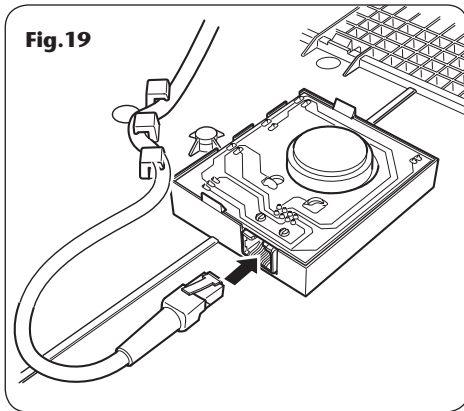

## COMMISSIONING

**IMPORTANT:** Before commissioning make sure both the electrical connection cover and ceiling are in place.

The unit has two fan speeds and two heat settings in any combination.

A single audible signal confirms a change in speed has been effected. A double bleep confirms the unit is in full heat mode. The unit can also be used in fan only mode.

Establish the electrical supply to the pull cord switch assembly by replacing any fuses and activating the RCD device.

Operate the pull switch to connect mains power to the unit. Momentarily, all three LED's will flash on but only the green LED will remain on.

### Test Sequence

Carry out the functions shown in **Table C**.

When first operated you may experience an odour from the unit, this will be due to the heating elements being operated for the first few times. This odour should quickly disappear.

Overheating is a sign that something is wrong. If the reason for overheating is not obvious then switch off the unit at the mains supply and contact Triton Customer Service for advice.

**DO NOT attempt any repairs as there are no user serviceable parts in the unit.**

The body dryer has a 10-minute maximum run time after which the unit will switch itself off.

To restart the dryer reselect a setting; this prevents permanent operation of the dryer when a button is accidentally pressed.

Any associated electric shower should now be checked for functionality as shown in **Table D**.

FUNCTION	EFFECT
Press the Fan only button on the hand-held controller.	Fan will start up in slow mode. Air output from the unit will be at ambient temperature.
Press the Fan Fast button.	Fan speed increases to the maximum.
Press the Low Heat button.	First heat element is connected and warm air is felt.
Press the High Heat button.	Second heat element is connected and air temperature increases.
Press the Fan Slow button.	Fan speed decreases to lowest setting. Air temperature increases further.
Press the High Heat button.	Second heat element is disconnected. Air temperature decreases.
Press the Fan only button.	Fan runs at its slowest speed. Ambient temperature air will be felt from unit.
Press STOP button.	Fan stops.

**Table C**

If this works as it should, with the shower running, try to turn on the body dryer.	Circuitry in the unit should prevent the body dryer switching on and the shower switching off.
Switch the shower OFF.	Full functionality is returned to the body dryer controller.
END OF COMMISSIONING	

**Table D**

Fig.21

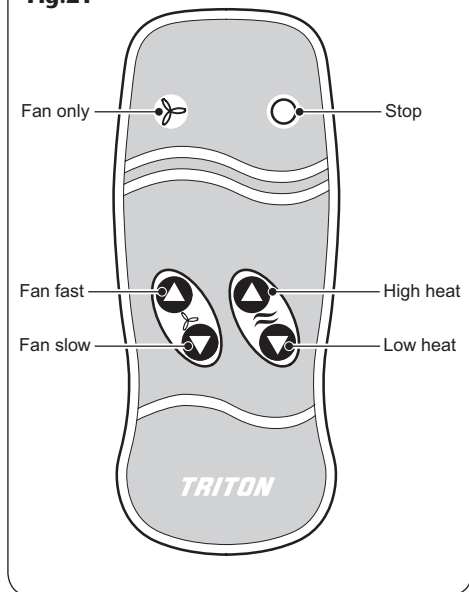

**Note:** As with most electrical appliances, **the unit must be switched off at the isolating switch when not in use.**

## OPERATING FUNCTIONS

### Normal use

The dryer has been designed for use in a bathroom or shower room for the purpose of personal body drying. The dryer **MUST NOT** be used for any other purpose.

The body dryer is designed to give maximum comfort and drying satisfaction.

The dryer is an extremely efficient personal body dryer and will heat a room rapidly.

It should be understood that when wet rapid evaporation results in a drop in body temperature. To maximise comfort and reduce drying time it is recommended that full heat and slow fan speed is selected immediately after exiting the shower or bath.

Typically, after a short period excess water on the skin will start to evaporate quickly and the user feels more comfortable with the fast speed setting and/or lower heat setting. Make these adjustments as required.

When first operated you may experience an odour from the unit, this will be due the heating elements being operated for the first few times. This odour should quickly disappear.

### Remote control handset (fig.21)

Works by infra red frequency transmissions and has a range of about five metres line-of-sight.

### Body dryer controller

Each time a button is depressed it is accompanied by either one or two bleeps. The functions are shown in **Table E**.

Pressing the OFF button turns off the dryer unit and returns power to the shower (if fitted). An audible jingle is generated to confirm that the dryer has been switched off.

### Off control

Power is always maintained to the dryer for control purposes but power to any associated electric shower will be switched off when the dryer is in use.

As a precaution against misoperation the dryer incorporates a 10 minute cut-off timer. If this is

activated then the reselection of a function on the remote controller will be required to restart the dryer.

### OVERHEAT CUT OUT

The body dryer is designed with your safety in mind. The dryer incorporates sophisticated protection circuitry that shuts down the power if for any reason the dryer should overheat.

In the unlikely event that this should occur during use both the red and orange LED's in the cover will be illuminated and the body dryer heaters and fan will have been turned off by the electrical safety circuitry.

When the red LED has extinguished the unit has cooled sufficiently for the body dryer to be safely switched on again. **The unit will not reset until after the red LED has extinguished.**

The orange LED remains on to show that an overheat situation has occurred and can only be reset when the power to the body dryer is removed. Use the pull cord switch assembly to disconnect then reconnect the electrical power.

Overheating is a sign that something is wrong, if the reason for overheating is not obvious or is a regular occurrence then advice or support should be sought from an approved service engineer or the manufacturer.

**DO NOT attempt any repairs as there are no user serviceable parts in the unit.**

FUNCTION	EFFECT
Press the Fan only button on the hand-held controller.	Fan will start up in slow mode (one bleep). Air output from the unit will be at ambient temperature.
Press the Fan Fast button.	Fan speed increases to the maximum (one bleep).
Press the Low Heat button.	First heat element (4.5kW) is connected and warm air is felt (one bleep).
Press the High Heat button.	Second heat element (total 9.0kW) is connected and air temperature increases (two bleeps).
Press the Fan Slow button.	Fan speed decreases to lowest setting. Air temperature increases further (one bleep).
Press the High Heat button.	Second heat element is disconnected. Air temperature decreases (one bleep).
Press the Fan only button.	Fan runs at its slowest speed. Ambient temperature air will be felt from unit (one bleep).
Press STOP button.	Fan stops (longer bleep).

Table E

### **CLEANING**

Always isolate the power supply when cleaning.

DO NOT use detergents, abrasive cleaning powder, or polish of any kind on the cover.

Wipe with a dry cloth to remove dust and a damp cloth (not wet) to clean off stains.

Make sure that dust or fluff does not accumulate on the inlet mesh, this could lead to overheating of the element. Use a vacuum cleaner at regular intervals to remove dust or fluff.

### **SERVICING**

Should any servicing or maintenance be required then contact Triton Customer Service or a suitably qualified and competent electrician or service engineer.

## SPARE PARTS

<i>Ref.</i>	<i>Description</i>	<i>Spares No.</i>
-------------	--------------------	-------------------

### Complete unit

- |                                   |                                    |          |
|-----------------------------------|------------------------------------|----------|
| – Airobe model DR-103 version 1.1 |                                    |          |
| <b>1.</b>                         | Main PCB                           | 83309590 |
| <b>2.</b>                         | Heater element – single            | 83309600 |
| <b>3.</b>                         | Fan motor                          | 83309610 |
| <b>4.</b>                         | Run capacitor                      | 83309620 |
| <b>5.</b>                         | Cover, including:<br>PCB<br>Filter | 83309630 |
| <b>6.</b>                         | Handset                            | 83309640 |
| <b>7.</b>                         | Communication cord                 | 83309650 |

### Optional

- Body dryer fitting kit 1  
(for concrete ceilings)
- Body dryer fitting kit 2  
(for flat roofs)

## Service Policy

In the event of a complaint occurring, the following procedure should be followed:

- 1** Telephone Customer Service on +44 (0) 24 7637 2222 (+44 (0) 84 5762 6591 in Scotland and in Northern Ireland), having available the model number and power rating of the product, together with the date of purchase.
- 2** Triton Customer Service will be able to confirm whether the fault can be rectified by either the provision of a replacement part or a site visit from a qualified Triton service engineer.
- 3** If a service call is required the unit must be fully installed for the call to be booked and the date confirmed. In order to speed up your request, please have your postcode available when booking a service call.
- 4** It is essential that you or an appointed representative (who must be a person of 18 years of age or more) is present during the service engineer's visit and receipt of purchase is shown.
- 5** A charge will be made in the event of an aborted service call by you but not by us, or where a call under the terms of guarantee has been booked and the failure is not product related (i.e. electrical installation faults).
- 6** If the product is no longer covered by the guarantee, a charge will be made for the site visit and for any parts supplied.
- 7** Service charges are based on the account being settled when work is complete, the engineer will then request payment for the invoice. If this is not made to the service engineer or settled within ten working days, an administration charge will be added.

## Replacement Parts Policy

**Availability:** It is the policy of Triton to maintain availability of parts for the current range of products for supply after the guarantee has expired. Stocks of spare parts will be maintained for the duration of the product's manufacture and for a period of five years thereafter.

In the event of a spare part not being available a substitute part will be supplied.

**Payment:** The following payment methods can be used to obtain spare parts:

- 1** By post, pre-payment of pro forma invoice by cheque or money order.
- 2** By telephone, quoting credit card (MasterCard or Visa) details.
- 3** By website order, [www.tritonshowers.co.uk](http://www.tritonshowers.co.uk)

## TRITON STANDARD GUARANTEE

Triton Plc guarantee this product against all mechanical and electrical defects arising from faulty workmanship or materials for a period of two years for domestic use only, from the date of purchase, provided that it has been installed by a competent person in full accordance with the fitting instructions.

Any part found to be defective during this guarantee period we undertake to repair or replace at our option without charge so long as it has been properly maintained and operated in accordance with the operating instructions, and has not been subject to misuse or damage.

This product must not be taken apart, modified or repaired except by a person authorised by Triton Plc. This guarantee applies only to products installed within the United Kingdom and does not apply to products used commercially. This guarantee does not affect your statutory rights.

### *What is not covered:*

- 1** Breakdown due to: *a)* use other than domestic use by you or your resident family; *b)* wilful act or neglect; *c)* any malfunction resulting from the incorrect use or quality of electricity, gas or water or incorrect setting of controls; *d)* faulty installation.
- 2** Repair costs for damage caused by foreign objects or substances.
- 3** Total loss of the product due to non-availability of parts.
- 4** Compensation for loss of use of the product or consequential loss of any kind.
- 5** Call out charges where no fault has been found