

TRITON

**Millennium
Care
electric shower**



**Installation and
operating
instructions**

INSTALLERS PLEASE NOTE THESE INSTRUCTIONS ARE TO BE LEFT WITH THE USER

CONTENTS	Page
Important safety information	1
Introduction	2
Main components	3
Electrical requirements	4
Water requirements	6
Fitting the shower to the wall	8
Plumbing connections	9
Electrical connections	10
Replacing the cover	11
Commissioning	12
Operating the shower	14
Operating functions	16
Cleaning	17
Adjusting the showerhead	18
Instructions for installers and service engineers only	18
Spare parts	19
Fault finding	20
Notes for commissioning and in-service testing	24
Frequency of in-service testing	25
Guarantee, service policy, etc.	rear cover

To check the product suitability for commercial and multiple installations, please contact Triton's specification advisory service before installation.

Telephone: +44 (0) 87 0067 3767

Facsimile: +44 (0) 87 0067 3334

E mail: technical@triton.plc.uk

PLEASE READ THIS IMPORTANT SAFETY INFORMATION

- ◆ Products manufactured by Triton are safe and without risk provided they are installed, used and maintained in good working order in accordance with our instructions and recommendations.
- ◆ **WARNING: DO NOT operate shower if frozen, or suspected of being frozen. It must thaw out before using.**
- ◆ Do not operate the unit if the showerhead or spray hose becomes damaged.
- ◆ Do not restrict flow out of shower by placing showerhead in direct contact with your body.
- ◆ Do not operate the shower if water ceases to flow during use or if water has entered inside the unit because of an incorrectly fitted cover.
- ◆ **WARNING: If restarting the shower immediately after stopping, be aware that a slug of hot water will be expelled for the first few seconds.**

1 GENERAL

1.1 Isolate the electrical and water supplies before removing the cover.

1.2 Read all of these instructions and retain them for later use.

1.3 DO NOT take risks with plumbing or electrical equipment.

1.4 Isolate electrical and water supplies before proceeding with the installation.

1.5 The unit must be mounted onto the finished wall surface (on top of the tiles). Do not tile up to unit after fixing to wall.

1.6 Contact Customer Service (*see back page*), if any of the following occur:

a) If it is intended to operate the shower at pressures above the maximum or below the minimum stated.

b) If the unit shows a distinct change in performance.

c) If the shower is frozen.

1.7 If it is intended to operate the shower in areas of hard water (above 200 ppm temporary hardness), a scale inhibitor may have to be fitted. For advice on the Triton Scale Inhibitor, contact Triton Customer Service.

1.8 The showerhead must be cleaned regularly with descalent to remove scale and debris, otherwise restrictions to the flow on the outlet of the unit will result in higher temperatures and could also cause the Pressure Relief Device in the unit to operate.

1.9 This product is not suitable for mounting into steam rooms or steam cubicles.

2 PLUMBING

2.1 The plumbing installation must comply with Water Regulations, Building Regulations or any particular regulations as specified by Local Water Company or Water Undertakers and should be in accordance with BS 6700.

2.2 The supply pipe must be flushed to clear debris before connecting to the shower unit.

2.3 DO NOT solder pipes or fittings within

300 mm of the shower unit, as heat can transfer along the pipework and damage components.

2.4 DO NOT fit any form of outlet flow control as the outlet acts as a vent for the heater can.

2.5 DO NOT use excessive force when making connections to the flexible hose or showerhead, finger tight is sufficient.

2.6 All plumbing connections must be completed before making the electrical connections.

3 ELECTRICAL

3.1 The installation must comply with BS 7671 'Requirements for electrical installations' (IEE wiring regulations), building regulations or any particular regulations as specified by the local Electrical Supply Company.

3.2 This appliance MUST be earthed.

3.3 In accordance with 'The Plugs and Sockets etc. (Safety) Regulations 1994', this appliance is intended to be permanently connected to the fixed wiring of the electrical mains system.

3.4 Make sure all electrical connections are tight to prevent overheating.

3.5 Fuses do not give personal protection against electric shock.

3.6 To enhance electrical safety a 30mA residual current device (RCD) should be installed in all UK electric and pumped shower circuits. This may be part of the consumer unit or a separate unit.

3.7 Switch off immediately at isolating switch if water ceases to flow during use.

3.8 Other electrical equipment i.e. extractor fans, pumps must not be connected to the circuits within the unit.

3.9 Switch off at isolating switch when not in use. This is a safety procedure recommended with all electrical appliances.

3.10 As with all electrical appliances it is recommended to have the shower and installation checked at least every two years by a competent electrician to ensure there is no deterioration due to age and usage.

INTRODUCTION

This book contains all the necessary fitting and operating instructions for your Triton Millennium Care electric shower.

Take time to read this book thoroughly and familiarise yourself with all instructions before commencing installation.

Please keep it for future reference.

The shower installation must be carried out by a suitably qualified person and in the sequence of this instruction book.

Care taken during the installation will ensure a long, trouble-free life from your shower.

SPECIFICATIONS

Electrical

Nominal power rating at 240V	Nominal power rating at 230V
8.5kW – (40A MCB rating)	7.8kW – (40A MCB rating)

Water

Inlet connection – 15 mm diameter.

Outlet connection – ½" BSP male thread.

Entry Points

Water – top, bottom, back or right.

Cable – top, bottom, back or right.

Materials

Backplate, cover, controls, showerhead – ABS.

Sprayplate – Acetal.

Elements – Minerally insulated corrosion resistant metal sheathing.

Dimensions (mm)

Height – 413, Width – 243, Depth – 97

Standards and Approvals

Splashproof rating IPX4

Complies with the requirements of current British and European safety standards for household and similar electrical appliances.

Complies with requirements of the British Electrotechnical Approvals Board (BEAB).

Meets with Compliance with European Community Directives (CE).

Replacement parts can be ordered from Customer Service. See *σ σ* 'for details and part numbers.

Due to continuous improvement and updating, specification may be altered without prior notice.

UNDERSTANDING THE MILLENNIUM CARE

a. Temperature/flow rate

The temperature control on the unit can be adjusted to provide shower temperatures between 35°C and 47°C.

Alternatively, the shower temperature can be restricted by moving the set-up link on the cover PCB to one of three positions, providing 41°C, 43°C or 47°C maximum.

IMPORTANT: To comply with BEAB CARE MARK requirements (use in healthcare or special needs environment), the set-up link must be set to 41°C maximum (*σ*)

At a selected temperature the unit will maintain a set flow rate.

The unit has 4 flow options:

- 1 Cold (4.5 litres per minute)
- 2 Low flow (3 litres per minute)
- 3 Medium flow (4.5 litres per minute)
- 4 High flow (max 6 litres per min – average)

If the unit is unable to maintain a stated flow rate for the temperature required due to variations in incoming water temperature/pressure, the unit will supply the maximum flow rate possible.

Note the maximum flow rate for the given temperature will be greater in the Summer than in the Winter because of the variance in the ambient mains water supply.

b. Temperature stabilisation

The shower will maintain the user's selected temperature to within +1°C when pressure changes occur (within the pressure range stated in the site requirements) and when there are fluctuations in voltage (within the UK supply tolerance) and inlet water temperature.

c. Safety cut-out

The unit is fitted with a non-resettable over-temperature safety device. In the event of abnormal operation which could cause unsafe temperatures within the unit, the device will disconnect the heating elements. It will require a visit from a qualified engineer to determine the nature of the fault and replace the safety device, once the unit has been repaired.

IMPORTANT: When first installed the heater can will be empty. It is essential the can should contain water before the elements are switched on. As this unit has electronic control, it is vital that the commissioning procedure is followed as instructed. Failure to carry out this operation will result in damage to the unit and will invalidate the guarantee.

MAIN COMPONENTS

Inside the unit (fig.1)

1. Top cable or pipe entry
2. Terminal block
3. Cover screw fixing - top
4. Wall fixing hole - top
5. Can & element assembly
6. Stepper motor
7. Transformer on PCB
8. Splitter valve
9. Thermal safety cut-out
10. Flow meter
11. Triac switches
12. Connector for cover ribbon
13. Cold feed to mixing chamber
14. DC motor
15. Flow control valve
16. Pressure Relief Device (PRD)
17. Solenoid valve
18. Inlet sensor
19. Cable and pipe exit from top entry
20. Earth post
21. Mixing chamber
22. Shower outlet
23. Outlet sensor
24. Wall fixing hole - bottom
25. Cover screw fixing - bottom
26. Shower inlet
27. Bottom cable or pipe entry
28. Side entry for cable or pipe
29. Back entry area for pipe and cable
30. Trimplate

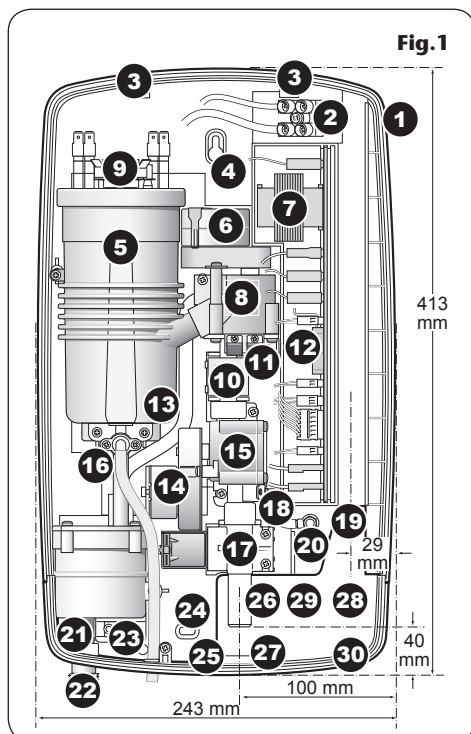

Fig.1

Inside the unit (fig.2)

31. Control PCB
32. Set-up link (factory set at 'purge' position)
33. 20-way ribbon
34. Potentiometer (cover not shown)
35. Start/stop switch

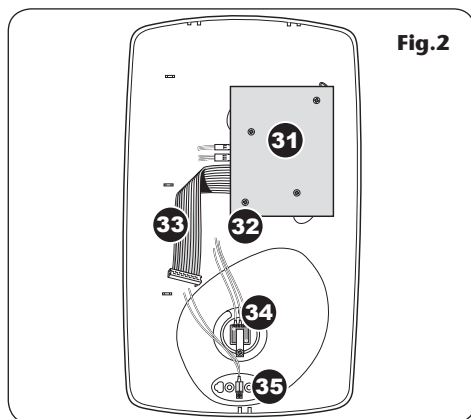

Fig.2

ELECTRICAL REQUIREMENTS

WARNING! THIS APPLIANCE MUST BE EARTHED

The installation, supply cable and circuit protection must conform with BS7671 (IEE wiring regulations) and be sufficient for the amperage required.

The following notes are for guidance only:

- 1 The shower must only be connected to a 230-240V ac supply. If you are installing a shower with a kilowatt rating above 9kW, it is advisable to contact the local electricity supply company.
- 1.1 The electrical rating of the shower is shown on the rating label (fig.3) within the unit.

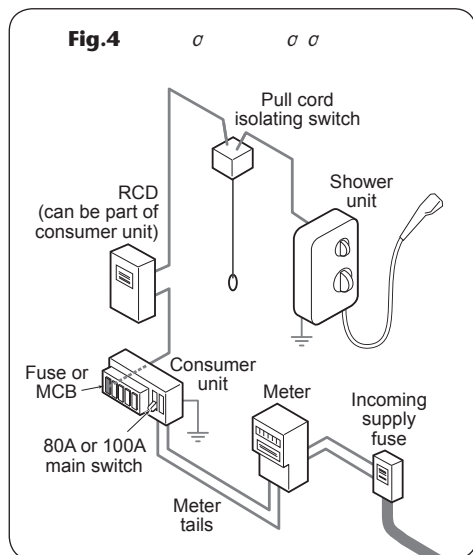
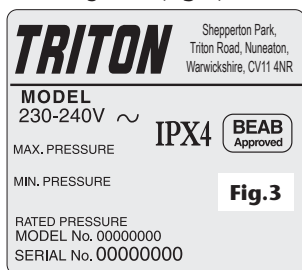

- 2 Before making any sort of electrical connection within the installation make sure that no terminal is live. If in any doubt, switch off the whole installation at the consumer unit.
- 3 The shower must be connected to its own independent electrical circuit. IT MUST NOT be connected to a ring main, spur, socket outlet, lighting circuit or cooker circuit.
- 3.1 The electrical supply must be adequate for the loading of the unit and existing circuits.
- 4 Check your consumer unit (main fuse box) has a main switch rating of 80A or above and that it has a spare fuse way which will take the fuse or MCB necessary for the shower (fig.4).
- 4.1 If your consumer unit has a rating below 80A or if there is no spare fuse way, then the installation will not be straightforward and may require a new consumer unit serving the house or just the shower.
- 4.2 You will need to contact the local electricity company. They will check the circuit and carry out what is necessary. They will also check the main bonding.
- 5 The earth continuity conductor of the electrical installation must be effectively connected electrically to all exposed metal parts of other appliances and services in the room in which the shower is to be installed, to conform to current IEE regulations.

Table A

CIRCUIT PROTECTION		
unit rating	MCB	cartridge fuse
7.0kW	30/32A	30A
7.5kW	32A	35A
8.0kW	40A	35A
8.5kW	40A	45A
9.0kW	40A	45A
9.5kW	40/45A	45A
10.5kW	45A	45A

- 5.1** All exposed metallic parts in the bathroom must be bonded together using a cable of at least 4 mm² cross sectional area. These parts include metal baths, radiators, water pipes, taps and waste fittings.
- 6** For close circuit protection DO NOT use a rewireable fuse. Instead use a suitably rated miniature circuit breaker (MCB) or cartridge fuse (**see table A**).
- 6.1** In the interest of electrical safety a 30mA residual current device (RCD) should be installed in all UK electric and pumped shower circuits. This may be part of the consumer unit or a separate unit.
- 7** A 45 amp double pole isolating switch with a minimum contact gap of 3 mm in both poles must be incorporated in the circuit.
- 7.1** It must have a mechanical indicator showing when the switch is in the OFF position, and the wiring must be connected to the switch without the use of a plug or socket outlet.
- 7.2** The switch must be accessible and clearly identifiable, but out of reach of a person using a fixed bath or shower, except for the cord of a cord operated switch, and should be placed so that it is not possible to touch the switch body while standing in a bath or shower cubicle. It should be readily accessible to switch off after using the shower.
- 8** Where shower cubicles are located in any rooms other than bathrooms, all socket outlets in those rooms must be protected by a 30mA RCD.
- 9** The current carrying capacity of the cable must be at least that of the shower circuit protection (**see table B**).
- 9.1** To obtain full advantage of the power provided by the shower, use the shortest cable route possible from the consumer unit to the shower.
- 9.2** It is also necessary to satisfy the disconnection time and thermal constraints which means that for any given combination of current demand, voltage drop and cable size, there is a maximum permissible circuit length.
- 10** The shower circuit should be separated from other circuits by at least twice the diameter of the cable or conduit.
- 10.1** The current rating will be reduced if the cabling is bunched with others, surrounded by thermal loft or wall insulation or placed in areas where the ambient temperature is above 30°C. Under these conditions, derating factors apply and it is necessary to select a larger cable size.
- 10.2** In the majority of installations, the cable will unavoidably be placed in one or more of the above conditions. This being so, it is strongly recommended to use a minimum of 10 mm cabling throughout the shower installation.
- 10.3** In any event, it is essential that individual site conditions are assessed by a competent electrician in order to determine the correct cable size and permissible circuit length.

Table B

Twin and earth PVC insulated cable Current carrying capacity		
Installed in an insulated wall	In conduit trunking	Clipped direct or buried in a non-insulated wall
6 mm ² 32A	6 mm ² 38A	6 mm ² 46A
10 mm ² 43A	10 mm ² 52A	10 mm ² 63A
16 mm ² 57A	16 mm ² 69A	16 mm ² 85A

Note: Cable selection is dependent on derating factors

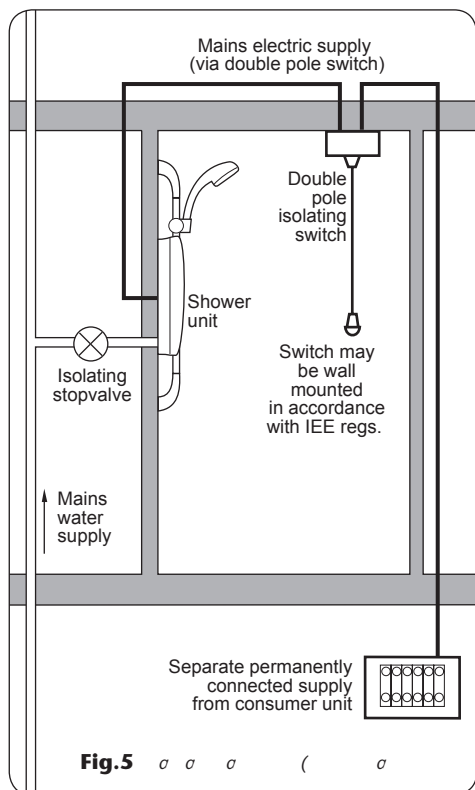

WATER REQUIREMENTS

The installation must be in accordance with Water Regulations/Bylaws.

To ensure activation of the heating elements, the shower must be connected to a mains water supply with a minimum running pressure of 100kPa (1.0 bar) at a minimum flow rate of eight litres per minute.

The maximum static pressure must be no greater than 1 000kPa (10 bar).

If in any doubt, the pressure should be checked.

Note: If the stated flow rate are not available, it may not be possible to achieve optimum performance from the unit throughout the year.

The water supply can be taken from a cold water storage cistern provided there is a minimum head of ten metres. Minimum head is the vertical distance from the base of the cistern to the showerhead. It must be an independent supply to the shower only.

If it is intended to operate the shower at pressures above the maximum or below the minimum stated, contact Customer Service for advice.

Fig.5 shows a typical system layout.

DO NOT use jointing compounds on any pipe fittings for the installation.

IMPORTANT: To comply with BEAB Care Mark In-Service Testing Procedures, the mains water supply stopvalve should be located close to the shower unit.

SITING OF THE SHOWER

IMPORTANT: If installing onto a tiled wall always mount the unit on the surface of the tiles. NEVER tile up to the unit.

Refer to **fig.6** for the correct siting of the shower.

Position the unit where it will NOT be in direct contact with water from the showerhead.

Position the shower unit vertically.

Allow enough room between the ceiling and the shower to access the cover top screws.

Note: Water regulations require the showerhead be 'constrained by a fixed or sliding attachment so that it can only discharge water at a point not less than 25 mm above the spill-over level of the relevant bath, shower tray or other fixed appliance'. Because of the nature of the extended hose and riser rail, the showerhead would normally be able to be placed within a bath, basin or shower tray. In this case a double check valve, or similar, must be fitted in the supply pipework to prevent back-flow.

Pressure relief safety device

A pressure relief device (PRD) is designed into the shower unit which complies with European standards. The PRD provides a level of appliance protection should an excessive build up of pressure occur within the shower.

DO NOT operate the shower with a damaged or kinked shower hose, or a blocked showerhead which can cause the PRD to operate.

When commissioning, the showerhead must be removed from the flexible hose, while at the same time the temperature control must be at the minimum flow position. Failure to follow this procedure may also cause the PRD to operate.

Make sure the shower is positioned over a bath or shower tray because if the PRD operates, then water will eject from the bottom of the unit.

Should this happen, turn off the electricity and water supplies to the shower at the isolating switch and stopvalve. Contact Customer Service for advice on replacing the PRD

WARNING!
The shower must not be positioned where it will be subjected to freezing conditions.

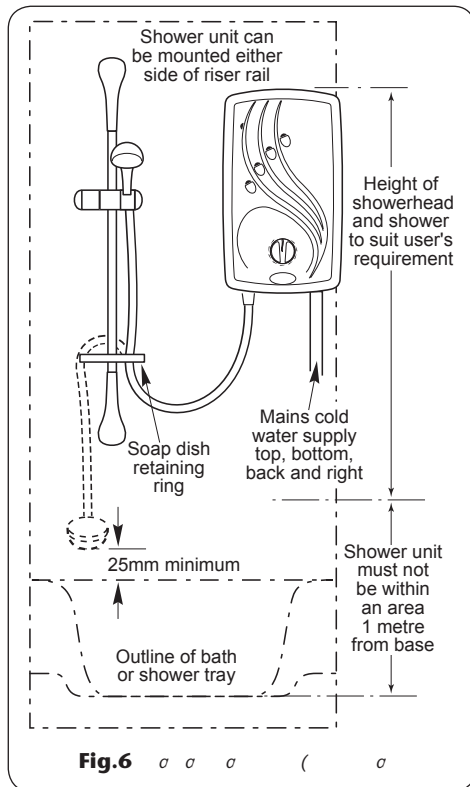
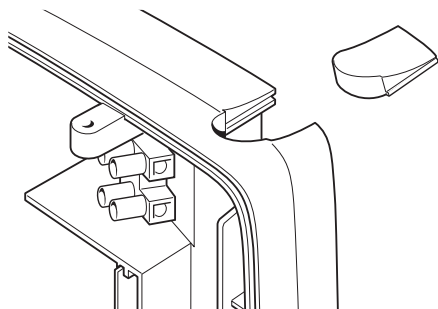
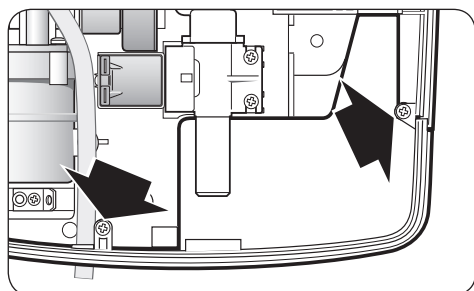
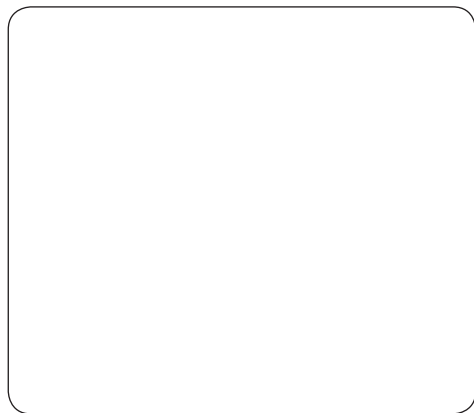

Fig.6 σ σ σ (σ

IMPORTANT: The unit must be mounted on a flat surface which covers the full width and length of the backplate. It is important that the wall surface is flat otherwise difficulty may be encountered when fitting the cover and subsequent operation of the unit may be impaired.



FITTING THE SHOWER TO THE WALL

Note: The control knob is an integral part of the cover – DO NOT attempt to remove it.

Unscrew the cover retaining screws (**fig.7**) and lift the cover from the backplate. To allow access to the pipe and cable connections, unscrew the two screws (**fig.8**) and remove the trimplate.

Entry positions for the mains water and cable supplies are from the top, bottom, back, or the right-hand side.

Note: Deviations from the designated entry points will invalidate product approvals.

If bottom entry is chosen for the mains water and cable, fit the appropriate trim in the top of the backplate (**fig.9**).

If top entry is chosen for the mains water and cable, fit the appropriate trim in the bottom of the trimplate (**fig.10**).

If side entry is required, the trimplate will have to be cut out. Carefully remove the appropriate area by using a knife or junior hacksaw (**fig.11**).

If installing a feed pipe from the rear or bottom, the centre of the inlet valve to the wall surface is 21.5 mm (**fig.12**).

Note: If entry is from the rear, the nut of the compression fitting will be partially behind the surface of the wall (**fig.12**). This area MUST be left clear when plastering over the pipework in order to make the nut accessible for future adjustments.

After choosing the site for the shower, use the backplate as a template and mark the two fixing holes (**fig.13**). Drill and plug to suit the fixing screws supplied. (

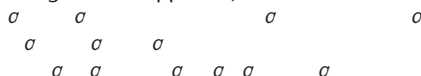

Screw the top fixing screw into position leaving the base of the screw head protruding 6 mm out from the wall.

Hook the backplate over the top screw and fit the bottom fixing screw into position.

Do not fully tighten the screws at this stage, as the fixing holes are elongated to allow for out of square adjustment after the plumbing connections have been completed.

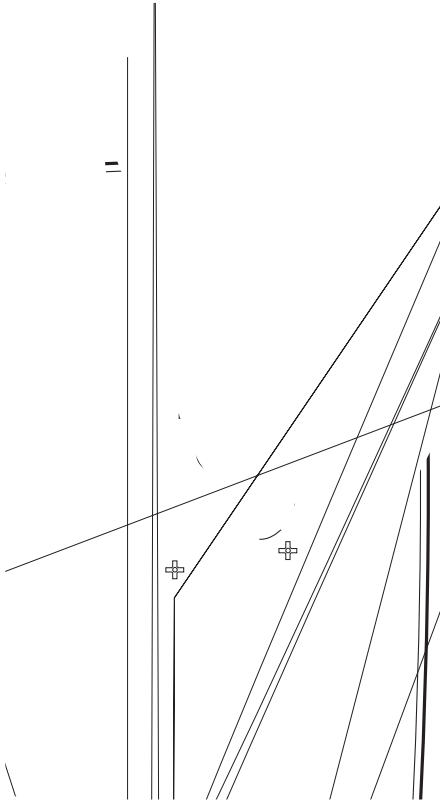

Once the flushing out has been completed, DO NOT PRESS THE STOP/START BUTTON but stop the water flow only by switching off the electricity supply to the shower at the isolating switch.

Setup link procedure

Unscrew the top and bottom retaining screws (**fig.7**) again and remove the cover from the backplate. It is not necessary to disconnect the 20-way ribbon cable as long as it is convenient to support the cover with one hand while moving the setup link with the other.

DO NOT let the cover dangle with the weight taken by the cable.

The setup link is located on the bottom left corner of the control PCB inside the cover (**fig.20**).

Apart from the 'purge' position, there are three other sets of pins on which the link can be placed as indicated (**fig.21**). These represent the maximum temperature restrictions (41°C, 43°C, or 47°C) of the shower when the temperature control is turned fully clockwise to '10'.

For normal use, place the link on the right-hand set of pins (47°C maximum — **fig.22**).

For situations where the main usage of the shower is for the elderly or young children, then place the link on either of the other two sets of pins (41°C or 43°C). This will restrict the maximum temperature to these limits should the temperature control otherwise be accidentally turned up too high.

Replacing the cover

Carefully locate the cover into the backplate, ensuring wires are not trapped, and guide into position.

Whilst applying slight pressure to the front cover, secure in position with the three retaining screws.

Turn the electric supply back on at the isolating switch.

Fit the showerhead to the flexible hose and place in showerhead holder.

The shower is ready for normal operation.

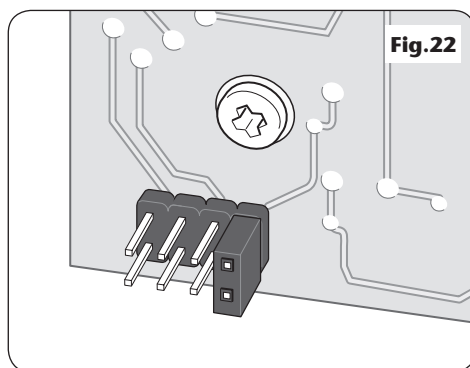
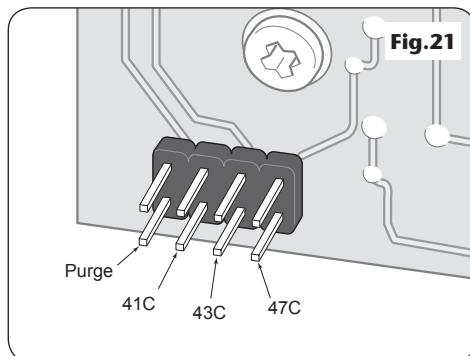

BEAB CARE MARK COMMISSIONING AND IN-SERVICE TESTING

To comply with the BEAB Care Mark requirements (for use in a healthcare or special needs environment):

1. You **MUST** follow the commissioning procedure given on Pages 26 – 28.
2. The setup link **MUST** be set over the 41°C pins (**fig.32**) limiting the outlet water temperature to 41°C maximum.
3. In-service testing must be carried out on a regular basis as given on pages 27 – 29.

Medium maintains a maximum flow rate of 4.5 litres per minute regardless of the temperature control position. The shower automatically adjusts to maintain the flow rate at the selected temperature and not to increase more than +1°C of the setting.

High allows the maximum flow possible for your selected temperature. The shower automatically adjusts to provide the highest flow rate achievable at the selected temperature and not to increase more than +1°C of the setting. This setting should be regarded as normal for optimum shower performance throughout the year.

Note: If the unit is unable to maintain a selected flow rate for the temperature required due to variations in incoming water temperature/pressure, the unit will supply the maximum flow rate possible.

Adjusting the shower temperature

The water temperature is altered by adjusting the temperature control (**fig.23**).

For a cooler shower temperature, turn the temperature control anti-clockwise towards the lower numbers.

For a hotter shower, turn the temperature control clockwise towards the higher numbers.

After obtaining your preferred showering temperature, the number can be remembered and left as the normal setting.

Note: It is advisable to be certain that the showering temperature is satisfactory by testing with your hand BEFORE stepping under the showerhead.

There will always be a time delay of a few seconds between selecting a temperature and the water reaching the stable temperature.

CAUTION: It is recommended that persons who may have difficulty understanding or operating the shower controls should not be left unattended whilst showering.

Special consideration should be given to young children and the less able bodied.

Note: In normal use, it is in order to leave the water supply permanently on to the shower unit, but as with most electrical appliances, **the unit must be switched off at the isolating switch when not in use.**

WARNING!

After any servicing of mains water supply, always ensure the unit is started on COLD in order to purge any air in the pipework.

Fig.24

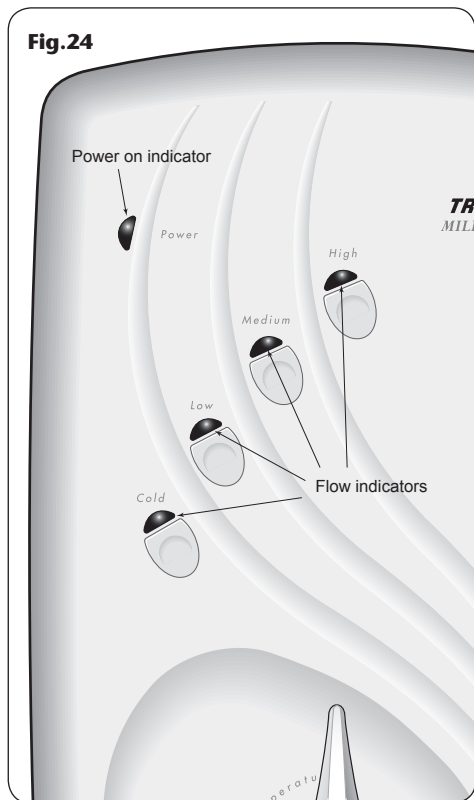

OPERATING FUNCTIONS

Power on indicator (fig.24)

When the electricity supply to the shower is switched on at the isolating switch, the 'power' indicator will light, and will remain lit until the power is switched off again at the isolating switch.

Note: Whenever power is switched on at the isolating switch, the shower will run through a start-up routine and the LED indicators will light up in sequence for a few seconds.

Flow indicators (fig.24)

Above each flow button there is an LED which indicates the flow option in use.

Phased shutdown

In use, when the start/stop button is pressed, power is switched off to the elements. Water continues to flow for a few seconds, flushing out any remaining hot water. This ensures the next immediate user will not receive a slug of hot water if standing under the showerhead when starting the shower.

Low flow sensor

Should the mains water pressure fall below the minimum specified operating pressure, the low flow LED will flash continuously and the unit will turn off. When pressure returns to normal the shower can be restarted by pressing the start or flow buttons. If the unit fails to return to normal operation it will be necessary to have the water supply and unit checked.

Safety cut-out

The unit is fitted with a non-resettable over-temperature safety device. In the event of abnormal operation which could cause unsafe temperatures within the unit, the device will disconnect the heating elements. It will require a visit from a qualified engineer to determine the nature of the fault and replace the safety device, once the unit has been repaired.

CLEANING

DO NOT use abrasive or solvent cleaning fluids. The shower unit, riser rail, hose, etc. should be cleaned using a soft cloth and warm water.

It is advised before cleaning, to turn the isolation switch off, thus avoiding the shower being accidentally switched on.

IT IS IMPORTANT TO KEEP THE SHOWERHEAD CLEAN TO MAINTAIN THE PERFORMANCE OF THE SHOWER. The hardness of the water will determine the frequency of cleaning. For example, if the shower is used every day in a very hard water area, it may be necessary to clean the showerhead on a weekly basis.

Sprayplate and cartridge removal

There is no need to remove the showerhead from the hose.

Using the removal tool supplied (**fig.25**), locate the three raised 'bosses' into the three recesses in the sprayplate. Hold in firmly and twist anti-clockwise (**fig.26**). This movement may turn the cartridge assembly as well until it reaches a 'STOP'.

Hold the cartridge firmly and continue to twist anti-clockwise. Having loosened the sprayplate sufficiently, it can be unscrewed and removed completely (**fig.27**).

To remove the cartridge, hold firmly and turn anti-clockwise until it unscrews from the showerhead (**fig.28**).

Clean the sprayplate and cartridge with a suitable brush or preferably leave them to soak overnight in a mild proprietary descaler. Ensure all traces of scale are removed and thoroughly rinse in clean water afterwards.

Before replacing the sprayplate and cartridge, switch the power back on at the isolating switch, direct the hose and showerhead to waste and press the 'COLD' button.

This operation will flush out any loose scale deposits in the unit and showerhead. Stop after approximately thirty seconds.

Refit the sprayplate and cartridge by screwing clockwise. Use the tool to screw in the sprayplate tight.

WARNING!

DO NOT use 'powerful' abrasive or solvent cleaning fluids when cleaning the shower as they may damage the plastic fittings.



SPARE PARTS

Ref	Description	Part No.
1.	Terminal block & wires	82200520
2.	Heater can assembly 8.5kW	84500410
3.	Stepper motor	22008460
4.	Power PCB	7072240
5.	Splitter valve assembly	83305670
6.	Triac switch assembly	82300580
7.	Flow meter assembly	83305650
8.	Pressure Relief Device	82800450
9.	Flow control valve and motor assembly	82600580
10.	Mixing chamber assembly	83305640
11.	Solenoid valve assembly	83305780
12.	Inlet sensor	22008190
13.	Outlet sensor	22008200
14.	Trimplate	7052227
—	Wire kit	83306520
15.	Cover assembly	83305870
16.	Cover PCB (8.5kW)	83305680
17.	Potentiometer	83305760
18.	Start/stop switch	83305770
19.	Extension lever	83305760
—	Potentiometer cover	22010180

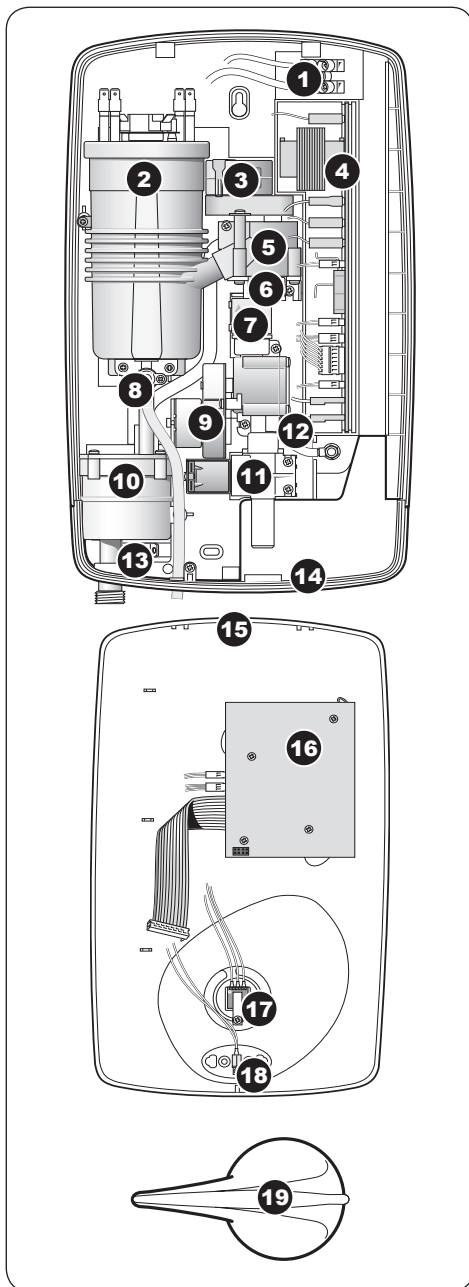

FAULT FINDING

IMPORTANT: Switch OFF the electricity at the mains supply and remove the circuit fuse before removing the cover from the shower while attempting any fault finding inside the unit.

Problem/Symptom	Cause	Action/cure
1. Shower inoperable	1.1 Interrupted power supply.	1.1.1 Blown fuse or circuit breaker. Check supply. Renew or reset fuse or circuit breaker. If it fails again, consult a qualified electrician.
	1.2 Unit malfunction.	1.2.1 Contact Customer Service for advice.
2. Water too hot.	2.1 Temperature control incorrect setting.	2.1.1 Turn anti-clockwise.
	2.2 Unit malfunction.	2.2.1 Contact Customer Service for advice.
3. Water too cool or cold.	3.1 Temperature control incorrect setting.	3.1.1 Turn clockwise.
	3.2 Setup link fitted on a lower temperature setting.	3.2.1 Isolate unit at isolating switch. Re-position setup link onto higher temperature pins (see 'Setup link procedure'). Re-adjust the temperature control.
	3.3 Unit malfunction.	3.3.1 Contact Customer Service for advice.
4. Unstable shower temperature/flow.	4.1 Blockages	4.1.1 Clean showerhead. Check inlet filter in solenoid and clean if necessary.
	4.2 Loose PCB connection	4.2.1 Check electrical connections on PCB's are correctly fitted.
	4.3 Unit malfunction.	4.3.1 Contact Customer Service for advice.
5. Pressure relief device has operated (water from PRD tube). Note:- Identify cause of operation before fitting new PRD unit. When fitting new PRD, follow commissioning procedure.	5.1 Blocked showerhead.	5.1.1 Clean or replace blocked showerhead cartridge and then fit a new PRD.
	5.2 Twisted/blocked flexible shower hose.	5.2.1 Check for free passage through hose. Replace the hose if necessary, then fit new PRD.
	5.3 Showerhead not removed whilst commissioning.	5.3.1 Fit new PRD. Commission unit with showerhead removed.

FAULT FINDING

Problem/Symptom	Cause	Action/Cure
6. Unit fails to turn off and water flowing. LED's flashing in sequence.	6.1 Link pin has not been removed from the 'purge' position or is incorrectly positioned.	6.1.1 Isolate unit at isolating switch. Re-position setup link onto correct temperature pins (see 'Setup link procedure').
7. Water continues to flow when unit is isolated at the isolating switch.	7.1 Debris in solenoid.	7.1.1 Contact Customer Service for advice.
8. Medium LED flashing continuously unit switches off.	8.1 Faulty inlet or outlet sensor.	8.1.1 Contact Customer Service.
9. Low LED flashing continuously unit switches off.	9.1 Low water pressure. 9.2 Faulty flow turbine. 9.3 Blocked inlet filter. 9.4 Blocked showerhead.	9.1.1 Wait for water pressure to return to normal, restart unit. 9.2.1 Contact Customer Service. 9.3.1 Clean the filter in solenoid. 9.4.1 Clean the showerhead.

It is advised all electrical maintenance/repairs to the shower should be carried out by a suitably qualified person.

In the unlikely event of unit failure other than detailed in the fault finding page, please contact Customer Service for advice.

It is advised all electrical maintenance/repairs to the shower should be carried out by a suitably qualified person.

WARNING

Before proceeding with any repair work or fault finding exercise, be aware that the printed circuit boards in this unit are static electricity sensitive and must be treated with great care. In order to prevent damage to the PCB's, a static control wrist strap must be worn before handling or removing the printed circuit boards.

COMMISSIONING

Where installed (Establishment): _____
 Installed/commissioned by: _____

Location of Unit: _____
 Signed: _____

Date: _____

Date of Commissioning		*Prior to Installation:				With unit turned on, set the temperature control to maximum (Position 10)													
1	Check unit designation matches the intended use	2	Check that the cover PCB link is set to 41°C	3	Mains water supply static pressure () bar	4	Mains water supply running pressure () bar	5	Mains water supply temperature () °C	6	Terminal voltage () %	7	Ambient temperature of water supply (ee Note 2).	8	Supply voltage at appliance Terminals (ee Note 5).	9	Maximum water temperature at shower outlet (ee Note 3).	10	Maximum outlet water temperature when water supply is restricted (ee Note 4).
	dd/mm/yy		41°C YES/NO		bar		bar		°C		V		°C		V		°C		°C

***Prior to Installation check:**

- a) The inlet filter of the shower is free from debris.
- b) The in-line check valves or other back-flow prevention devices are in good working order.
- c) Any isolating valves on the water main supplying the unit are fully opened.

Column 7: This test should be performed after pressing the 'COLD' button on the shower cover (Columns 8-10: These tests should be performed after resetting the shower to the default running settings by pressing the 'HIGH' button on the shower cover.

List of Test Equipment Used:

Measurement:	Test equipment used (Model, Make, etc)/Method used:	Identification:	Date of last calibration:
Supply water pressure			
Voltage			
Water temperature			

Note: All installation, commissioning and in-service testing must be undertaken by a suitably qualified engineer.

NOTES FOR COMMISSIONING AND IN-SERVICE TESTING

1. *Measuring the Shower Outlet Water Temperature*

With the shower running, position the showerhead horizontally and place a funnel under the water flow. Make sure that the funnel mouth collects all of the water emitted from the showerhead. Take a reading using a temperature probe in the collected water flowing from the outlet of the funnel.

Typical dimensions of a suitable funnel are:

Opening diameter: 110 mm,
Throat diameter: 15 mm.

2. *Measuring the Ambient Water Temperature of Mains Water Supply*

After pressing the 'Cold' button on the shower cover measure using the method described in (1.) above. This ensures that mains water at ambient temperature flows from the showerhead.

3. *Measuring the Heated Water from Shower Outlet*

After resetting the shower to the default setting (press the 'High' button on the shower cover) measure using the method described in (1.) above.

4. *Measurement of Heated Water from the Shower Outlet when Restricting the Mains Water Supply*

Progressively restrict the inlet water flow to the unit using the service valve (see page 6) until the 'Low' LED flashes (on the cover) and the shower shuts down with no water flow from the showerhead. Open the service valve slightly and restart the shower using the Stop/Start button. Record the resulting outlet water temperature using the method described in (1.) above. If this exceeds 43°C withdraw the shower from service and call Customer Service on +44 (0) 87 0067 3333.

Note: The service valve should be returned to the fully open position after this test.

5. *Measurement of Supply Voltage at Appliance Terminals*

Switch off the electricity at the mains supply and remove the circuit fuse. Remove the shower cover, taking care to position it so that it does not hang by the interconnecting ribbon cable.

Replace the circuit fuse and switch on the electrical mains supply. Take the AC voltage reading across the Live and Neutral screws of the mains terminal block.

Take care NOT to touch any other internal components of the shower. Switch off the electricity at the mains supply, remove the circuit fuse and replace the cover using the screws supplied.

Note: This test should only be performed by a suitably qualified engineer.

6. *When the Set Maximum Outlet Water Temperature has Changed Significantly*

If the set maximum outlet water temperature has changed significantly from the previous test results (greater than $\pm 1^\circ\text{C}$), check:

- a. That the outlet fittings (showerhead/shower hose) are free from restrictions and limescale.
- b. That the inlet filter of the shower is free from debris (see page 21).
- c. That in-line check valves or other back-flow prevention devices are in good working order.
- d. Any isolating valves on the water main supplying the unit are fully opened.

If, after making the above checks, an acceptable outlet water temperature is not achieved withdraw the shower from service and contact Triton Customer Care on +44 (0) 87 0067 3333.

FREQUENCY OF IN-SERVICE TESTING

First in-service test.	6 to 8 weeks after commissioning.
If no significant change in water outlet temperature (greater than $\pm 1^{\circ}\text{C}$) between commissioning and first test.	12 months after commissioning.
On going service testing.	Annually on the anniversary date when the unit was commissioned.

Table 1



A **MORCROS** Company

Service Policy

In the event of a complaint occurring, the following procedure should be followed:

1 Telephone Customer Service on +44 (0) 87 0067 3333 (+44 (0) 84 5762 6591 in Scotland and in Northern Ireland), having available the model number and power rating of the product, together with the date of purchase.

2 Triton Customer Service will be able to confirm whether the fault can be rectified by either the provision of a replacement part or a site visit from a qualified Triton service engineer.

3 If a service call is required the unit must be fully installed for the call to be booked and the date confirmed. In order to speed up your request, please have your postcode available when booking a service call.

4 It is essential that you or an appointed representative (who must be a person of 18 years of age or more) is present during the service engineer's visit and receipt of purchase is shown.

5 A charge will be made in the event of an aborted service call by you but not by us, or where a call under the terms of guarantee has been booked and the failure is not product related (i.e. scaling and furring, incorrect water pressure, pressure relief device operation, electrical installation faults).

6 If the product is no longer covered by the guarantee, a charge will be made for the site visit and for any parts supplied.

7 Service charges are based on the account being settled when work is complete, the engineer will then request payment for the invoice. If this is not made to the service engineer or settled within ten working days, an administration charge will be added.

Replacement Parts Policy

Availability: It is the policy of Triton to maintain availability of parts for the current range of products for supply after the guarantee has expired. Stocks of spare parts will be maintained for the duration of the product's manufacture and for a period of five years thereafter. In the event of a spare part not being available a substitute part will be supplied.

Payment: The following payment methods can be used to obtain spare parts:

1 By post, pre-payment of pro forma invoice by cheque or money order.

2 By telephone, quoting credit card (MasterCard or Visa) details.

3 By website order, www.tritonshowers.co.uk

Triton Plc
Triton Road
Nuneaton
Warwickshire CV11 4NR

TRITON STANDARD GUARANTEE

Triton Plc guarantee this product against all mechanical and electrical defects arising from faulty workmanship or materials for a period of two years for domestic use only, from the date of purchase, provided that it has been installed by a competent person in full accordance with the fitting instructions.

Any part found to be defective during this guarantee period we undertake to repair or replace at our option without charge so long as it has been properly maintained and operated in accordance with the operating instructions, and has not been subject to misuse or damage.

This product must not be taken apart, modified or repaired except by a person authorised by Triton Plc. This guarantee applies only to products installed within the United Kingdom and does not apply to products used commercially. This guarantee does not affect your statutory rights.

What is not covered:

1 Breakdown due to: **a)** use other than domestic use by you or your resident family; **b)** wilful act or neglect; **c)** any malfunction resulting from the incorrect use or quality of electricity, gas or water or incorrect setting of controls; **d)** faulty installation.

2 Repair costs for damage caused by foreign objects or substances.

3 Total loss of the product due to non-availability of parts.

4 Compensation for loss of use of the product or consequential loss of any kind.

5 Call out charges where no fault has been found with the appliance.

6 The cost of repair or replacement of pressure relief devices, showerheads, hoses, riser rails and/or wall brackets, isolating switches, electrical cable, fuses and/or circuit breakers or any other accessories installed at the same time.

7 The cost of routine maintenance, adjustments, overhaul modifications or loss or damage arising therefrom, including the cost of repairing damage, breakdown, malfunction caused by corrosion, furring, pipe scaling, limescale, system debris or frost.

Customer Service: ☎ +44 (0) 87 0067 3333

Scottish and Northern Ireland

Customer Service: ☎ +44 (0) 84 5762 6591

Trade Installer Hotline: ☎ +44 (0) 87 0067 3767
Fax: +44 (0) 87 0067 3334

www.tritonshowers.co.uk

E mail: technical@triton.plc.uk