

***mira***

mode

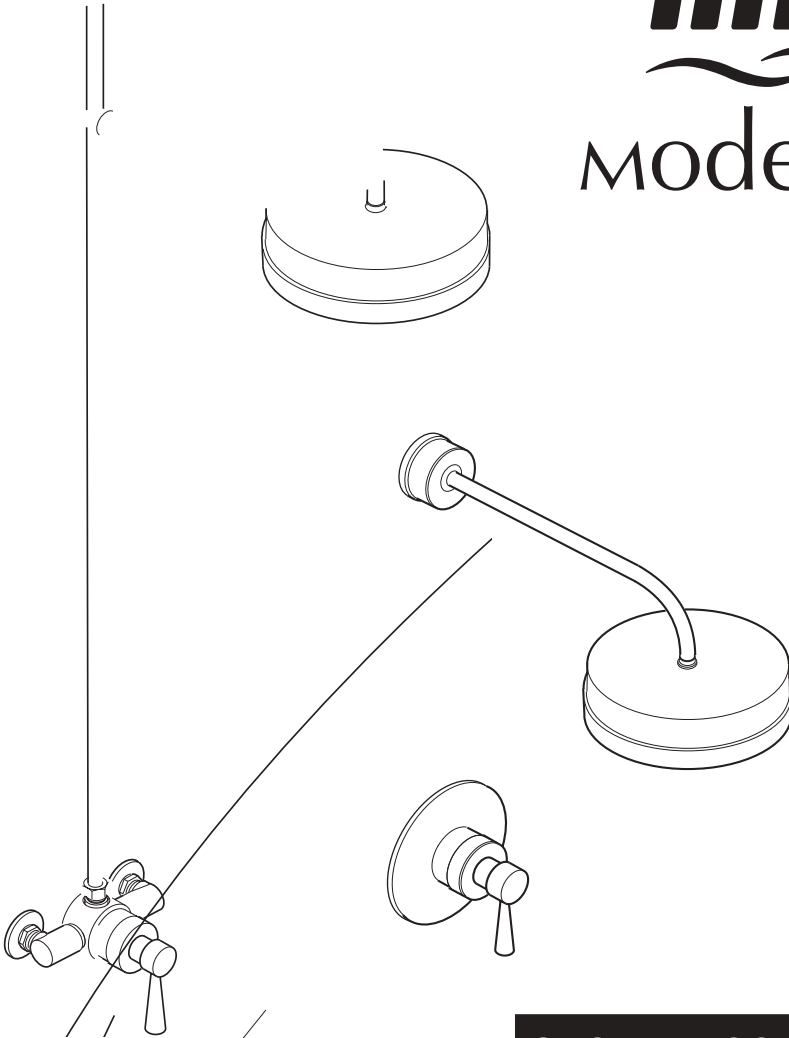

## SHOWER CONTROL

Installation

Operation &

Maintenance Guide

**THESE INSTRUCTIONS ARE TO BE LEFT WITH THE USER**

# INDEX

	<b>Page</b>
<b>INTRODUCTION</b>	<b>3</b>
<b>DESCRIPTION</b>	<b>3</b>
<b>SAFETY WARNINGS</b>	<b>4</b>
<b>PACK CONTENTS</b>	<b>5</b>
<b>DIMENSIONS</b>	<b>7</b>
<b>SPECIFICATION</b>	<b>9</b>
<b>INSTALLATION REQUIREMENTS</b>	<b>11</b>
<b>INSTALLATION</b>	<b>15</b>
<b>COMMISSIONING</b>	<b>29</b>
<b>OPERATION</b>	<b>30</b>
<b>FAULT DIAGNOSIS</b>	<b>31</b>
<b>MAINTENANCE</b>	<b>32</b>
<b>SPARE PARTS</b>	<b>34</b>
<b>CUSTOMER CARE</b>	<b>Back Cover</b>

# INTRODUCTION

Thank you for purchasing a quality Mira product. To enjoy the full potential of your new product, please take time to read this guide thoroughly, having done so, keep it handy for future reference.

Mira Mode Thermostatic mixing valves are specified to meet the highest standards of safety, comfort and economy as demanded by today's users. All Mira Mode products are designed, manufactured and supported in accordance with accredited BS EN ISO 9001:1994 Quality Systems.

This Manual covers all Mira Mode Thermostatic Mixing Valves manufactured from August 2000.

# DESCRIPTION

The Mira Mode thermostatic shower valve provides accurate temperature control and flow rates.

The Mira Mode is available in the following options;

Mira Mode - Surface Mounted

An exposed shower control for connection to rear top and bottom entry pipework. Refer to Specification for details on the pressure ranges.

Mira Mode - Recessed

A built-in shower control for connection to concealed pipework. Refer to Specification for details on the pressure ranges.

If you experience any difficulty with the installation or operation of your new shower control, then please refer to the **Fault Diagnosis** section, before contacting Kohler Plumbing Solutions. Our telephone and fax numbers can be found on the back cover of this guide.

## **SAFETY : WARNINGS**

Mira products are precision-engineered and should give continued superior and safe performance, provided:

1. They are installed, commissioned, operated and maintained in accordance with the recommendations given in this Manual.
2. Periodic attention is given, as necessary, to maintain the product in good functional order.

The function of a thermostatic mixing valve is to deliver water consistently at a safe temperature.

Provided it is installed, commissioned, operated and maintained within these recommendations, the risk of failure, if not eliminated, is reduced to the minimum achievable.

Anyone who may have difficulty understanding or operating the controls of any shower should be attended whilst showering. Particular consideration should be given to the young, the elderly, the infirm, or anyone inexperienced in the correct operation of the controls.

# PACK CONTENTS

!" Tick the appropriate boxes to familiarize yourself with the part names and to confirm that the parts are included.

## Mira Mode

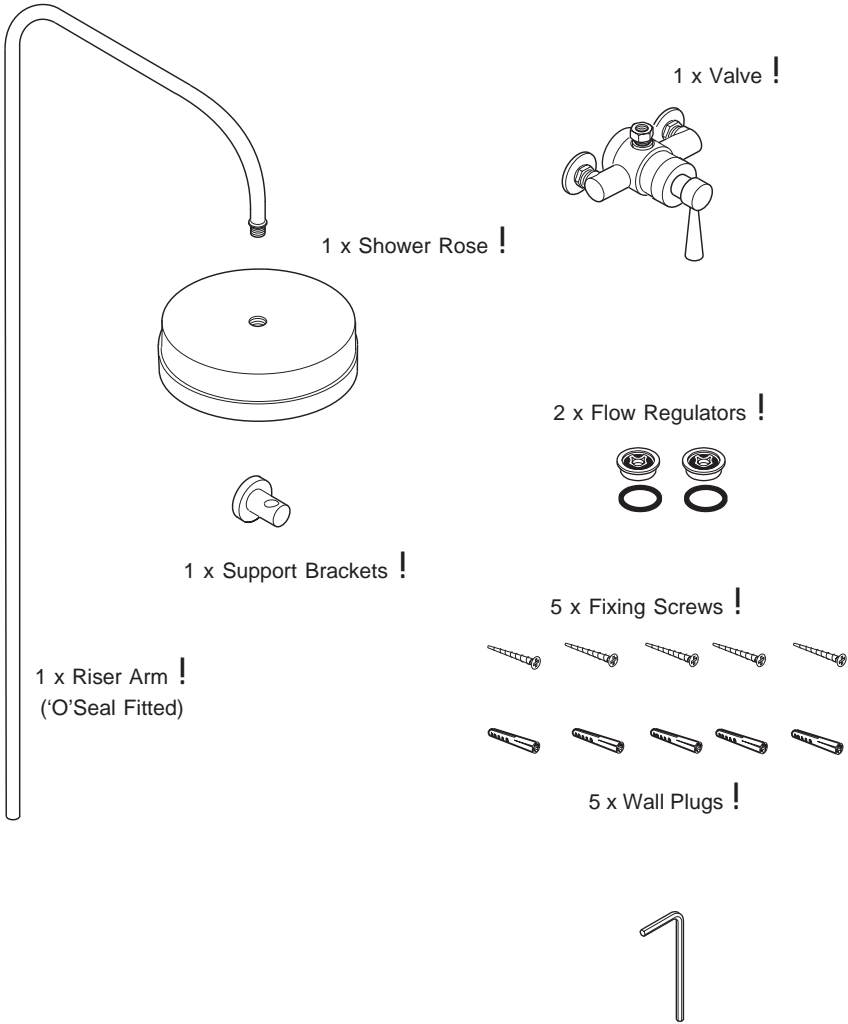

1 x Riser Arm !  
(‘O’Seal Fitted)

1 x Shower Rose !

1 x Valve !

2 x Flow Regulators !

1 x Support Brackets !

5 x Fixing Screws !

5 x Wall Plugs !

1 x Hexagonal Wrench !

## Documentation

1 x Installation, Operation and Maintenance Guide

1 x Customer Support Brochure

!  
!

!" Tick the appropriate boxes to familiarize yourself with the part names and to confirm that the parts are included.

## Mira Mode B

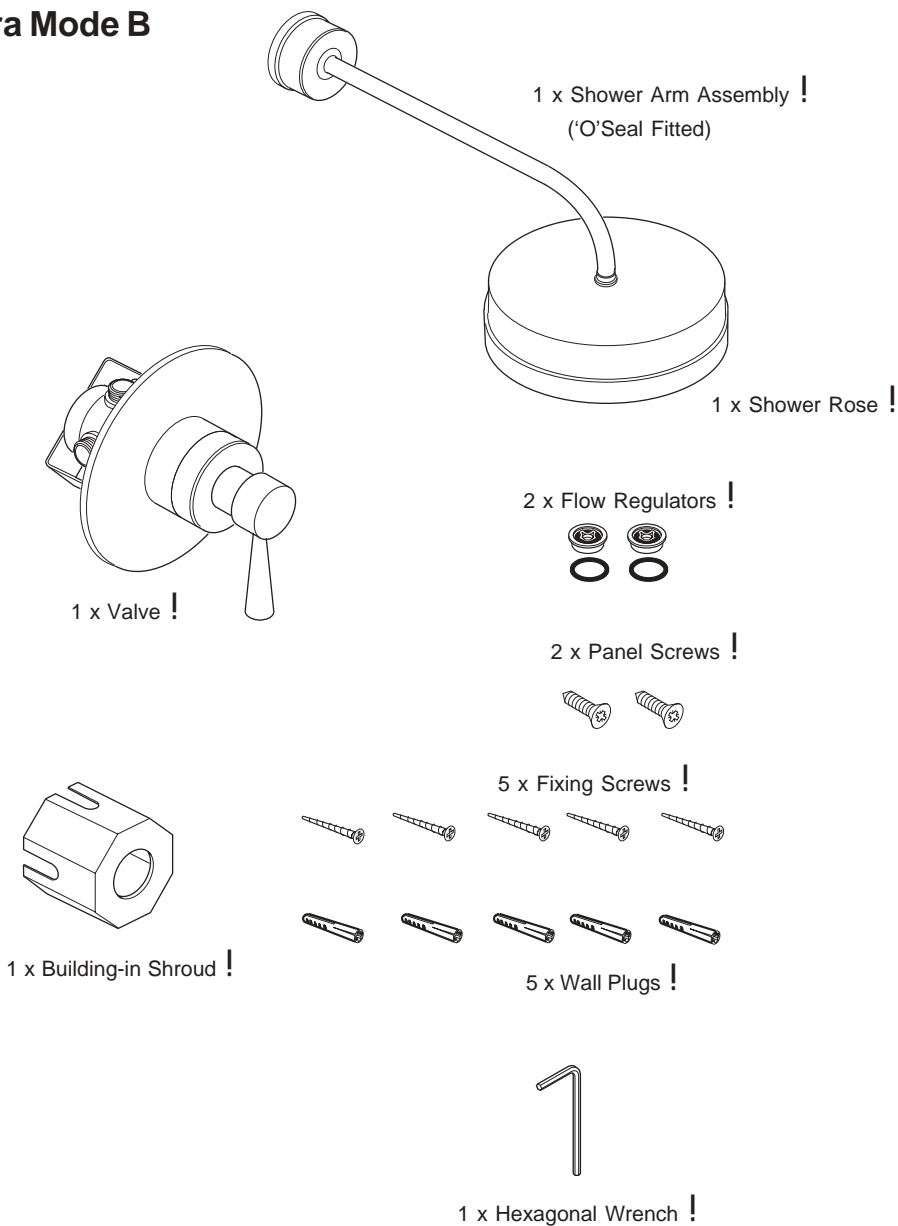

## Documentation

1 x Installation, Operation and Maintenance Guide

1 x Customer Support Brochure

!  
!

# DIMENSIONS

## Mira Mode

All dimensions are nominal and in mm

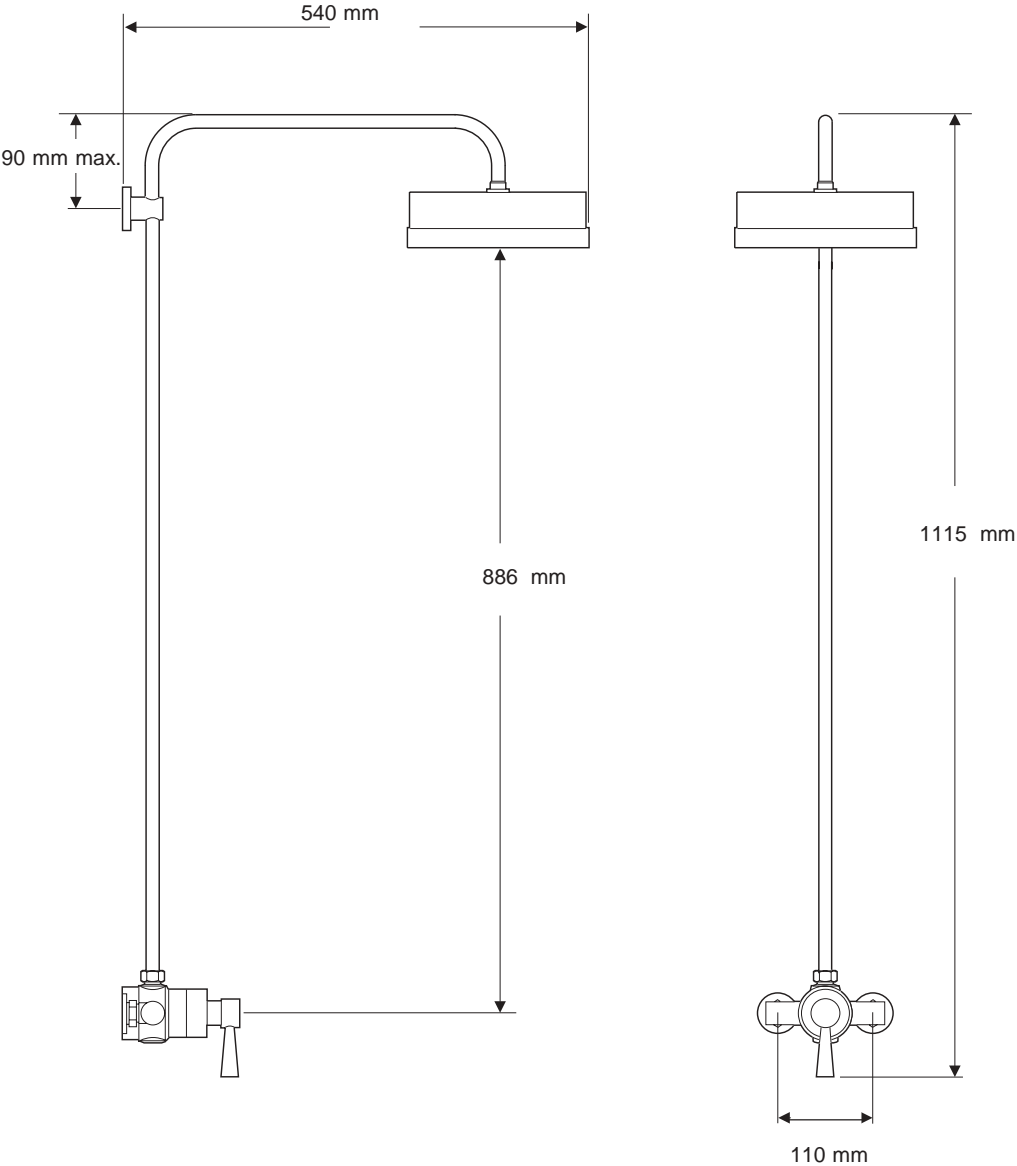

All dimensions are nominal and in mm



# SPECIFICATION

## Important Points:

1. The installation, commissioning and maintenance of this product must be carried out in accordance with instructions given in this Manual, and must be conducted by designated, qualified and competent personnel.
2. The plumbing installation must comply with the requirements of UK Water Regulations/Bye-laws (Scotland), Building Regulations or any particular regulations and practices, specified by the local water company or water undertakers. The installation should be carried out by a plumber or contractor who is registered, or is a member of, an association such as:
  - Institute of Plumbing (IOP), throughout the UK.
  - National Association of Plumbing, Heating and Mechanical Services Contractors (NAPH & MSC), England and Wales.
  - Scottish and Northern Ireland Plumbing Employers' Federation (SNIPEF), Scotland and Northern Ireland.
3. Mira products are precision-engineered and should give continued superior and safe performance, provided:-
  - they are installed, commissioned, operated and maintained in accordance with these recommendations and
  - periodic attention is given as necessary to maintain the product in good functional order. Recommended guidelines are given in the **MAINTENANCE**.
4. Warning: continued use of this product in conditions outside the limits listed in this section can severely affect the performance and reduce the effective service life, and can present potential risk to users.
5. Suitable for use with most modulating Instantaneous Gas Water Heaters.

For information on other specific applications or suitability, refer to Kohler Mira Ltd., or Local Agent.

# Operating Parameters: Pressures And Flow Rates

## Pressures

For optimum performance, maintained supply pressures should be nominally equal.

Maximum Pressure Loss Ratio: **5:1**

Minimum Maintained Pressure (gravity system): **0.1 bar**.  
(0.1 bar = 1 metre from base of cold tank to outlet of shower fitting)

Maximum Maintained Pressure: **6.0 bar**

Minimum Maintained Pressure (gas water heater): **1.0 bar**.

Maximum Static Pressure: **10 bar**.

## Flow Rates

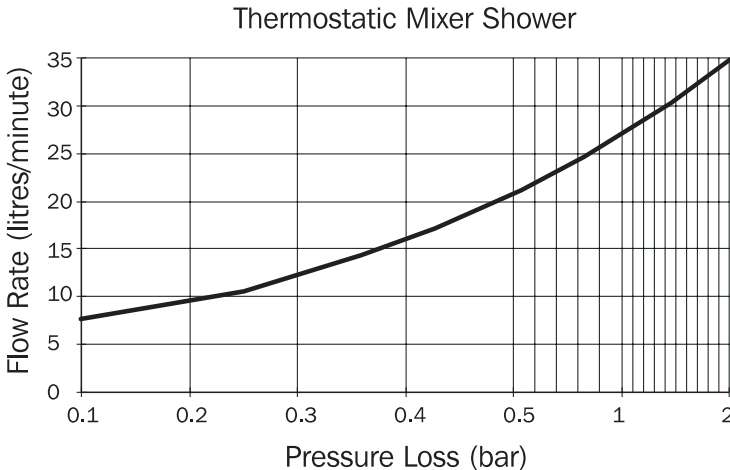

## Temperature Control

Minimum temperature differential between hot and outlet temperature: **10°C**

Optimum temperature control range: **35 - 45°C**

Maximum hot water temperature: **85°C** (BS 6700 recommends that the temperature of stored water should never exceed 65 °C. A stored water temperature of 60 °C is considered sufficient to meet all normal requirements and will minimise the deposition of scale in hard water areas).

The performance specification outlined below is achieved with outlet blend temperature set between 35 - 45°C and supplies of 15°C cold and 65°C hot with nominally equal pressures.

- Outlet blend temperature is maintained within 2°C with a 10°C change in hot or cold supply.
- Thermostatic shut down to seepage within 2 seconds if cold supply fails. This is achieved only if the hot supply temperature is 10°C above the set outlet blend temperature.

## Plumbing Connections









Inlet connectors are 15 mm compression

Outlet connector is 15 mm compression

Hot (H) and Cold (C) inlets are clearly marked and must be connected this way.

# INSTALLATION REQUIREMENTS

## Key to Symbols

	Isolating valve
	Mixing Valve
	Overflow Indicator
	Pressure Reducing Valve
	Twin Impeller Pump
	Single Impeller Pump
	Tempering Valve
	Mini Expansion Vessel

**Gravity Fed System** - The shower **MUST** be fed from a cold water cistern and hot water cylinder providing nominally equal pressure.

**Gas Heated System** - The shower **MUST** be installed with a gas water heater or combination boiler of a **fully modulating** design.

A fully modulating boiler is one where the draw off rate is indirectly controlling the gas flow to the boiler, producing a relatively constant hot water temperature.

**Unvented Mains Pressure System** - The shower can be installed with a unvented, stored hot water cylinder. Only “a competent person” as defined by the Building Regulations may fit this type of system.

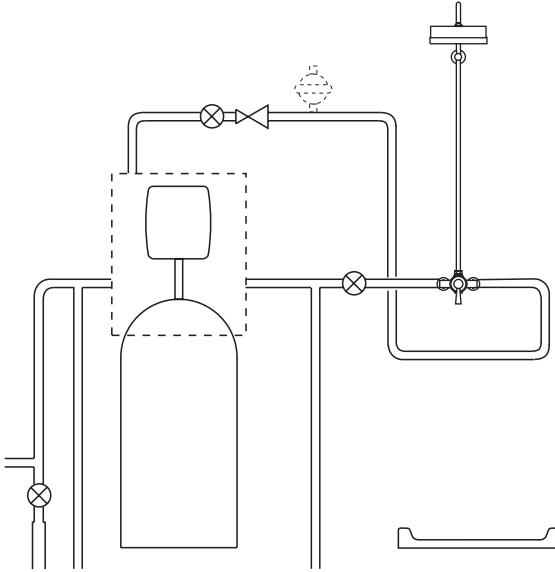

**Mains Pressurised Instantaneous Hot Water System** - The shower installed with systems of this type is supplied hot water via a tempering valve, this provides relatively constant hot water and the shower will compensate for temperature changes should they occur.

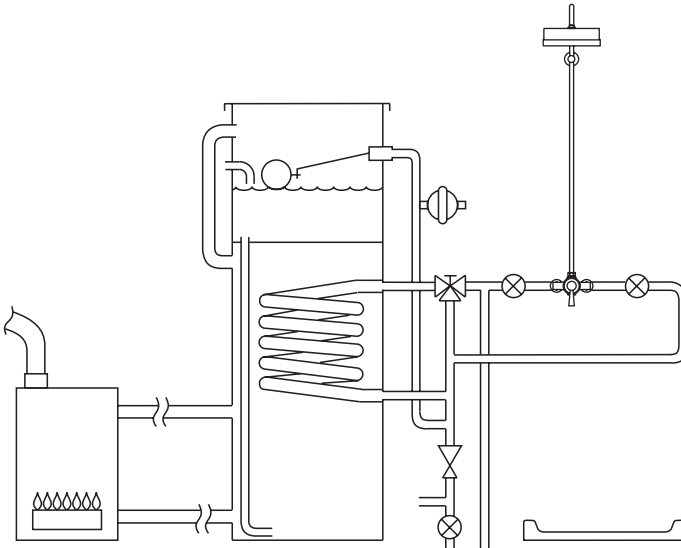

**Pumped System** - The shower can be installed with an inlet pump (twin impeller). The pump must be installed on the floor next to the hot water cylinder. Ensure hot cylinder vent pipe is arranged as shown to enable air separation.

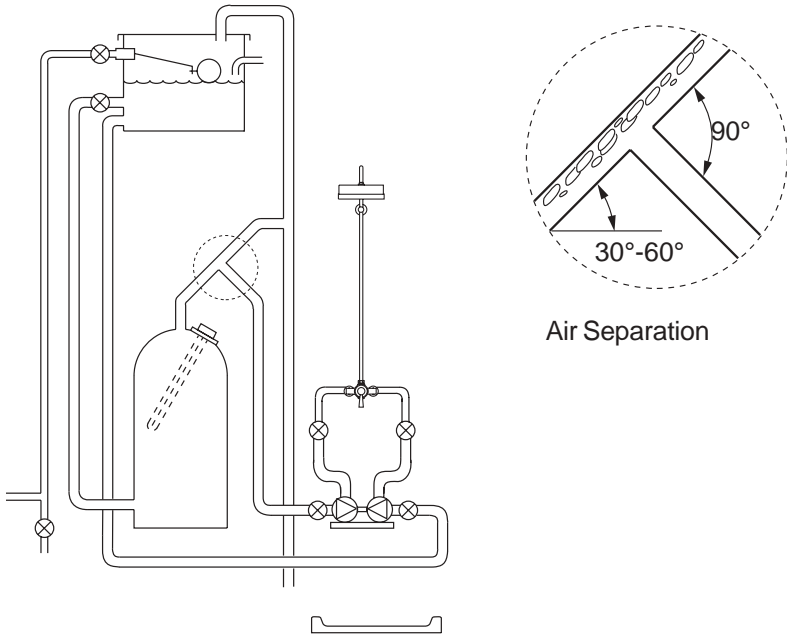

# INSTALLATION

## General

Installation must be carried out in accordance with these instructions, and must be conducted by designated, qualified and competent personnel.

1. Before commencing, ensure that the installation conditions comply with the information given in **SPECIFICATION**.
2. Care must be taken during installation to prevent any risk of injury or damage.
3. The mixing valve should be positioned for easy access during use and maintenance. All routine maintenance procedures can be conducted with the mixing valve body in place.
4. Conveniently situated isolating valves **must** be provided for maintenance.
5. Pipework must be rigidly supported.
6. Pipework dead-legs should be kept to a minimum.
7. Supply pipework layout should be arranged to minimise the effect of other outlet usage upon the dynamic pressures at the mixing valve inlets.
8. **To eliminate pipe debris it is essential that supply pipes are thoroughly flushed through before connection to the mixing valve.**

# Regulators

Two grey flow regulators are supplied with the product. They fit into the cold and/or hot inlet connectors for high pressure systems.

The selection table indicates when and where these can be fitted.

System	Cold Supply	Hot Supply
Gravity Fed System	X	X
Gas Water Heated System	✓	Optional
Mains Pressurised Instantaneous System	✓	Optional
Unvented Mains Pressure System		

**Optional**- Fit only if the force or flow from shower fitting is too great

## Fitting Regulator

1. Remove compression nut and olive from inlet elbow or connector.
2. Ensure 'o' seal is fitted to flow regulator and push inside until flange locates up against internal shoulder of inlet elbow/connector.
3. Make compression fitting using compression nut and olive.

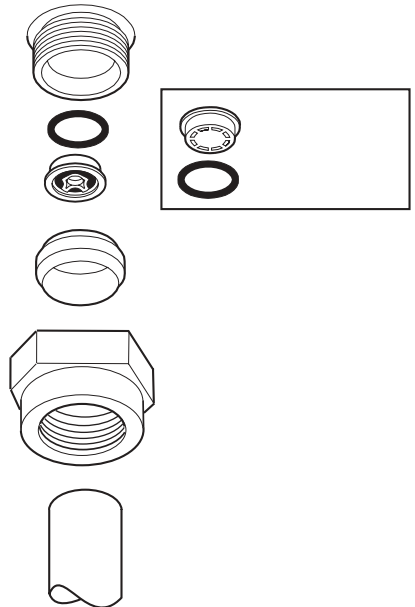

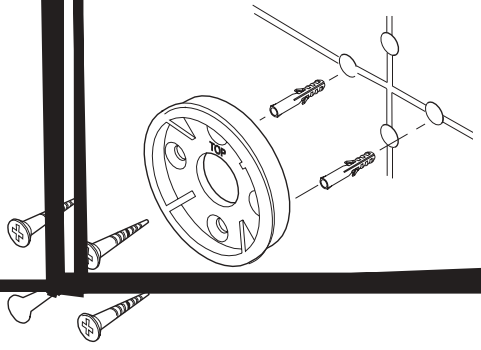

- Remove the plaster and brick/block to the required depth to conceal the pipework.

**Note!** Depth must be sufficient to prevent pipe concealing plates fouling on the plumbing elbows.

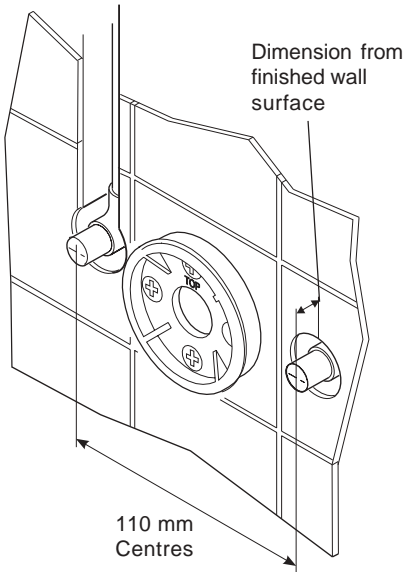

- Install the supply pipes. The pipes must be at 110 mm centres and project the following distances from the finished wall surface:

18 mm if flow regulators are being fitted.

21 mm if no flow regulators are fitted.

- Finish the surface of the wall as required.

- Slide the pipe concealing plates with 'O' seals fitted, nuts and olives over the hot and cold supply pipes.

- Thoroughly flush the hot and cold water supply pipes. The supplies must be clean and free from debris before connecting the shower control. Failure to do so may result in product malfunction.**

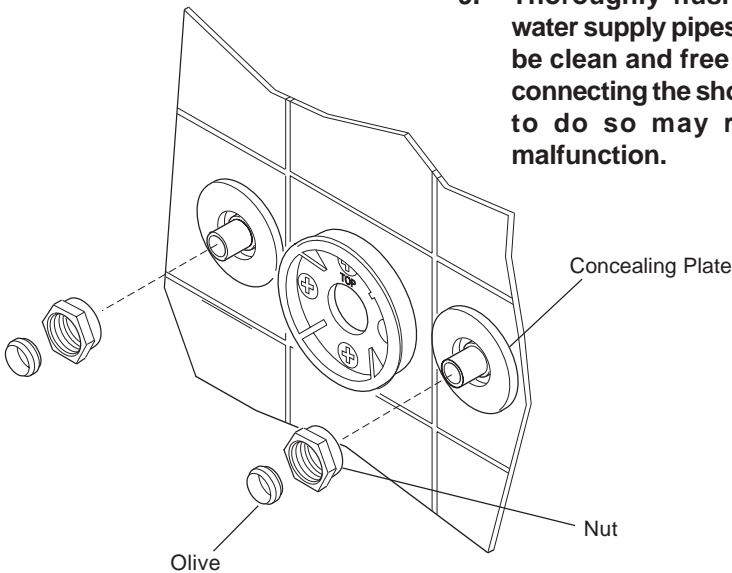

**10.** Locate the shower control on to the supply pipes and hold it in position.

**11.** Use a suitable spanner to tighten the nuts and pull the shower control onto the backplate. Protect the chromium plated surfaces with a cloth. Use the 2.5 mm A/F hexagon wrench (supplied) to tighten the two grub screw in the backplate. The grub screw will hold the shower control in position.

**12.** With the shower control turned off. Turn on the water supplies and check for any leaks.

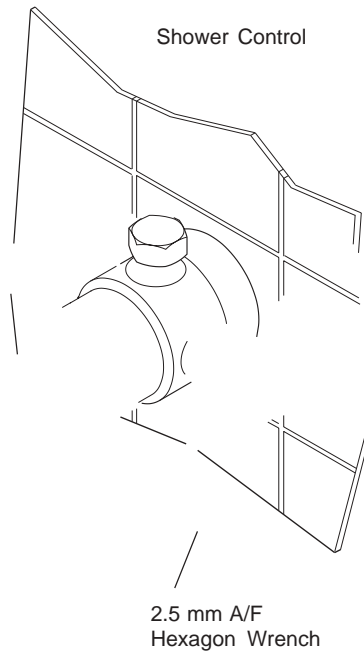

## Shower Fittings

1. Temporarily fit the shower arm and the support bracket to the outlet of the shower control and mark the hole position. Ensure the support bracket is fitted no more than 90mm below the top of the shower arm

**Note!** Use a spirit level or other device to ensure shower arm is vertical.

2. Remove the shower arm and support bracket.
3. Drill the wall and insert a suitable wall plug (supplied). Fit the wall plate to the wall.
4. Refit the shower arm and support bracket. Attach to the support bracket to the wall plate.
5. Ensure supply pipework is flushed through before fitting shower rose.

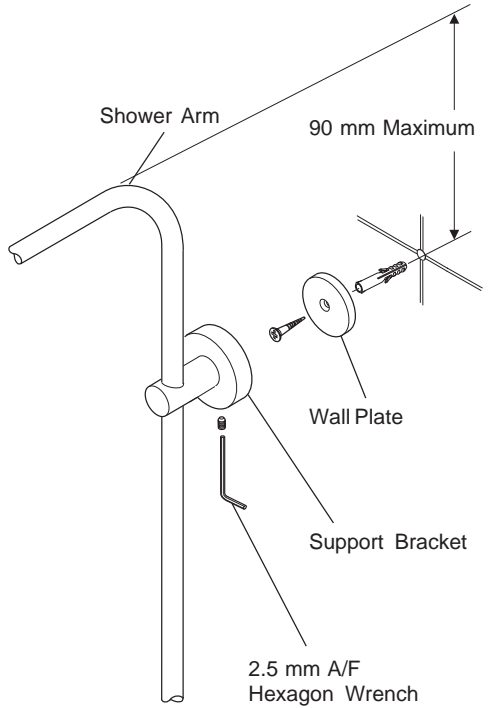

6. Attach the shower rose to the shower arm and tighten.

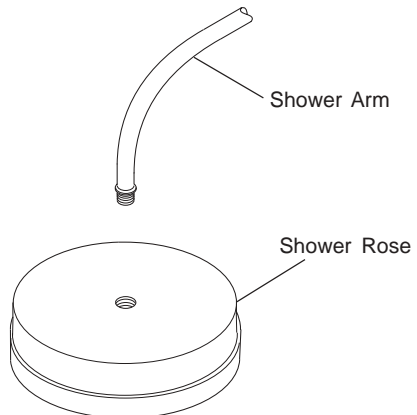

# Mira Mode B

## Solid and Dry-lined Walls

The built-in shower control is supplied with a support bracket (fitted) that can be used for installation into a solid or dry-lined wall structure. Installers may wish to consider other options such as fabricating rear supports using wooden noggins, however, these methods of fixing are beyond the scope of this guide.

1. Decide on a suitable position for mixer where all users can operate.

2. Determine the route for the incoming hot and cold supply pipework.

3. Determine the route for the outlet pipework.

4. Mark an opening sufficient to accommodate the shower control on the surface of the wall (124 mm diameter). A carbide tipped hole cutter can be used to produce the hole.

5. Mark the route of the supply and outlet pipes.

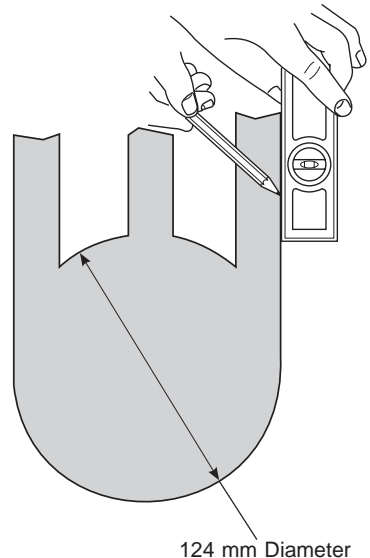

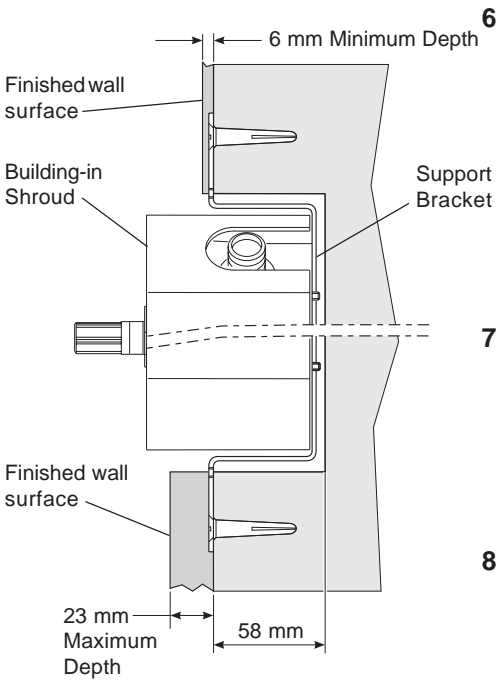

- Remove the plaster and brick/block for the shower control to a depth of between **76 and 93 mm** from the finished surface of the wall. The support bracket requires a clearance depth of **70 mm**, with a finished wall surface thickness of between **6 and 23 mm**.

- Remove the plaster and brick/block for the supply and outlet pipes.

- If necessary, remove the shower control from the support bracket. This will make installation easier.

- Mark the support bracket fixing hole positions. **The support bracket must be fixed at 45°.**

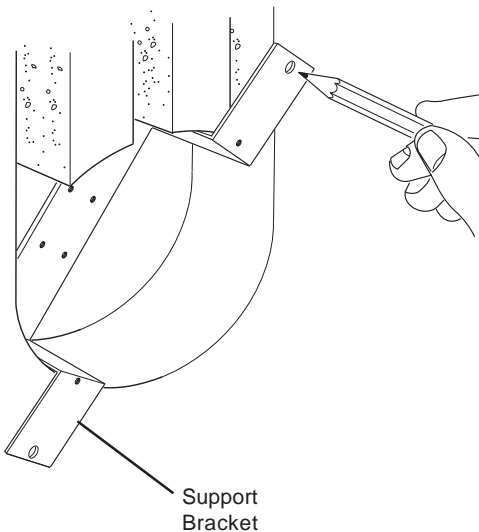

- Drill a 6.0 mm diameter hole at each of the marked positions and insert the wall plugs (supplied).

- Install the hot and cold supply pipes.

- Thoroughly flush the hot and cold water supply pipes. The supplies must be clean and free from debris before connecting the shower control. Failure to do so may result in product malfunction.**

- 13.** Fix the wall bracket to the support bracket using the four screws (supplied) and the shower control to the wall bracket, securing in position with the grub screw.

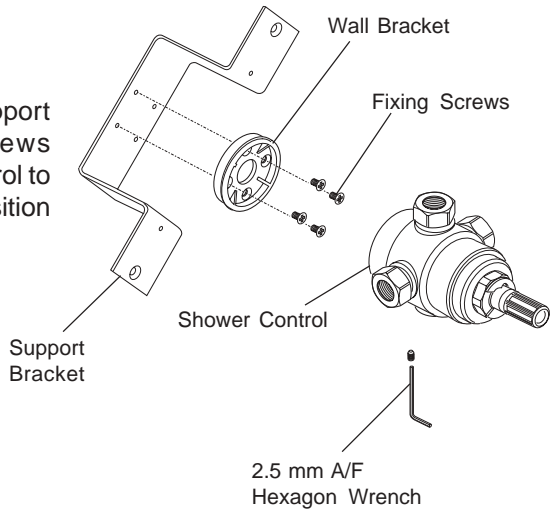

- 14.** Align the holes in the support bracket with the holes in the wall and secure the shower control with the fixing screws (supplied).

- 15.** Slide the compression nuts and olives over the supply pipes.

- 16.** Insert the hot and cold supply pipes fully into the shower control and slide the olives and compression nuts into place.

- 17.** Use a suitable spanner to tighten the compression nuts.

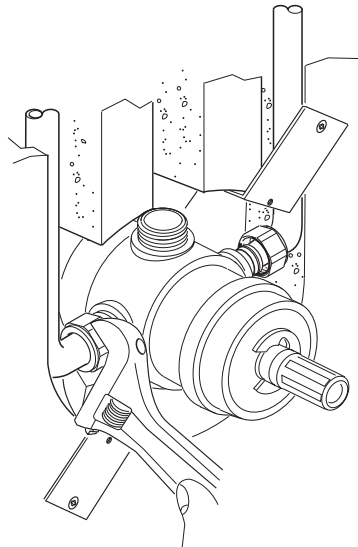

18. Install the outlet pipe (ensure that the final shower head position is at a suitable height for all users). Ensure the outlet pipe will protrude 15mm from the wall once the finishing coat of plaster and tiles are completed.
19. Slide the compression nut and olive over the outlet pipe.
20. Insert the outlet pipe fully into the shower control and slide the olive and compression nut into place.
21. Use a suitable spanner to tighten the compression nut.
22. Turn on the water supplies and check for any leaks.
23. Fit the building-in shroud and plaster and tile as necessary up to the sides of the building-in shroud. The finished surface of the wall must be between the minimum and maximum depths on the building-in shroud.
24. When the plaster/tiles have set remove the building-in shroud.
25. Install the plate seals and the concealing plate. Building-in Shroud Plate Seal

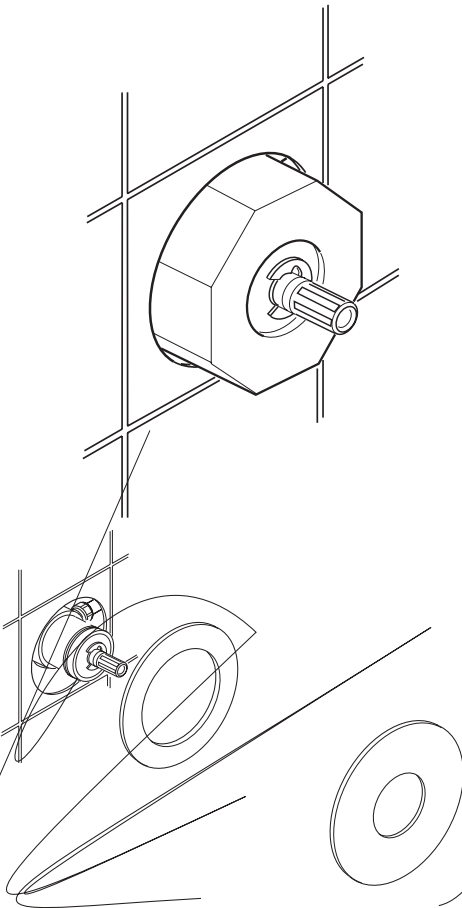

26. Fit the shield assembly in place and hand tighten it to secure the concealing plate and foam seals in place.

Make sure that the “Mode” logo is horizontal.

27. Fit the lever assembly and secure in position with the grub screw.

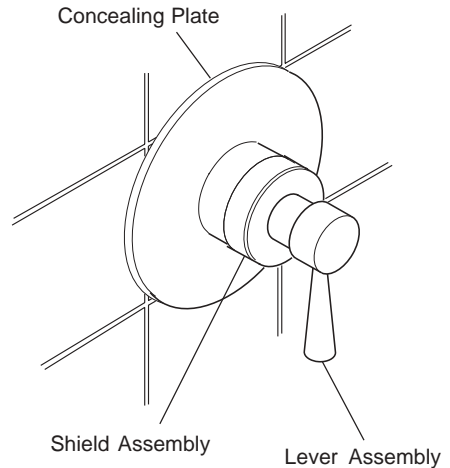

## Stud Partition, Shower Cubicle or Laminated Panel Walls

The built-in shower control is supplied with a support bracket that can be used to install the shower control into the front face of a stud partition wall structure or the rear face of a shower cubicle or laminated panel. The front face installation of the support bracket is only practical where plaster or tiles can conceal flanges of the bracket. Installers may wish to consider other options such as fabricating rear supports using wooden noggins, however, these methods of fixing are beyond the scope of this guide.

### Front Face Installation

1. Decide on a suitable position for mixer where all users can operate.
2. Determine the route for the incoming hot and cold supply pipework.
3. Determine the route for the outlet pipework.
4. Cut a 124 mm diameter hole in the panel and mark the fixing holes for the support bracket at 45°.

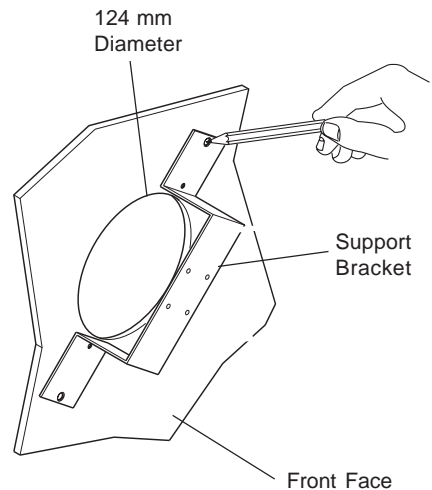

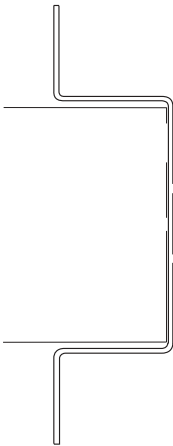

## Back Face Installation

**Note!** This installation is only possible with a finished wall thickness of between **4 and 21 mm**, and is normally associated with the installation into laminated panels or preformed shower cubicles.

1. Decide on a suitable position for mixer where all users can operate.
2. Determine the route for the incoming hot and cold supply pipework.
3. Determine the route for the outlet pipework.
4. Cut a 110 mm diameter hole in the panel and mark the fixing holes for the support bracket at 45°.
5. Drill and countersink the fixing holes to accept the M4 x 30 mm screws (supplied).
6. Install the hot and cold supply pipes.

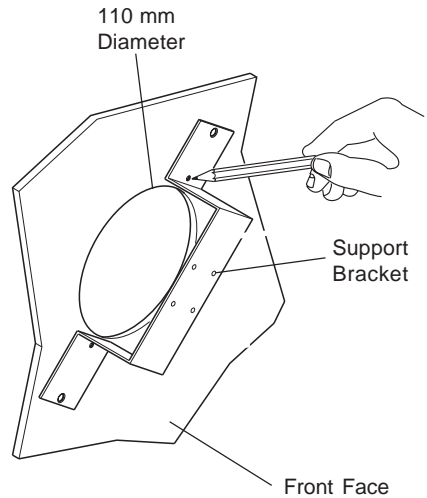

7. Fix the support bracket and shower control in position using the two M4 x 30 mm screws (supplied).

**Note!** The support bracket requires a clearance depth of **70 mm**, with a finished wall thickness of between **4 and 21 mm**.

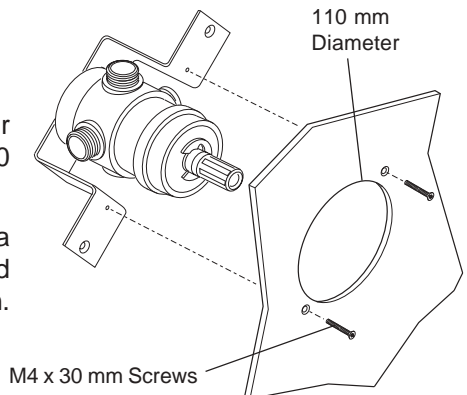

14. **Thoroughly flush the hot and cold water supply pipes. The supplies must be clean and free from debris before connecting the shower control. Failure to do so may result in product malfunction.**
15. Slide the compression nuts and olives over the supply pipes.
16. Insert the hot and cold supply pipes fully into the shower control and slide the olives and compression nuts into place.
17. Use a suitable spanner to tighten the compression nuts.
18. Continue the procedure as for solid and dry-lined walls.

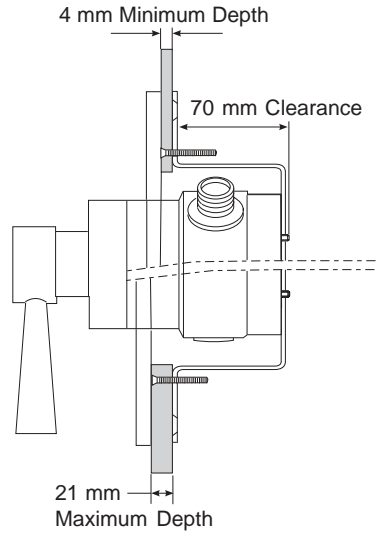

## Mira Mode B

### Shower Fittings

1. Fit the backplate to the wall over the protruding pipe (outlet pipe from shower control) with the fixing screws and wall plugs provided.
2. Slide the olive and compression nut over the supply pipes.

**Ensure the backplate is fitted as illustrated. Failure to do so may result in the outlet pipe becoming damaged when drilling or fixing with screws.**

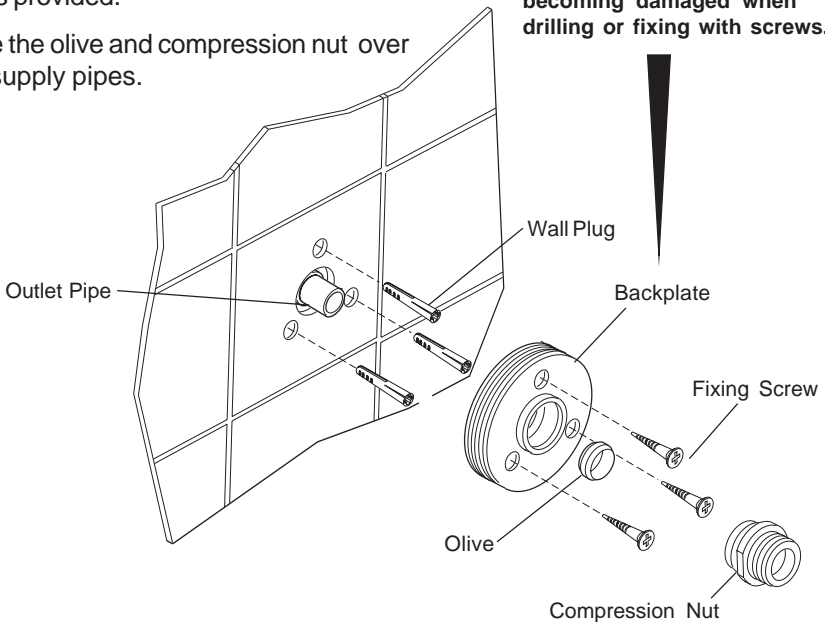

3. Fit the 'O' seal over the compression nut.
4. Fit the rigid pipe assembly over the compression nut and hand tighten the shroud onto the backplate.

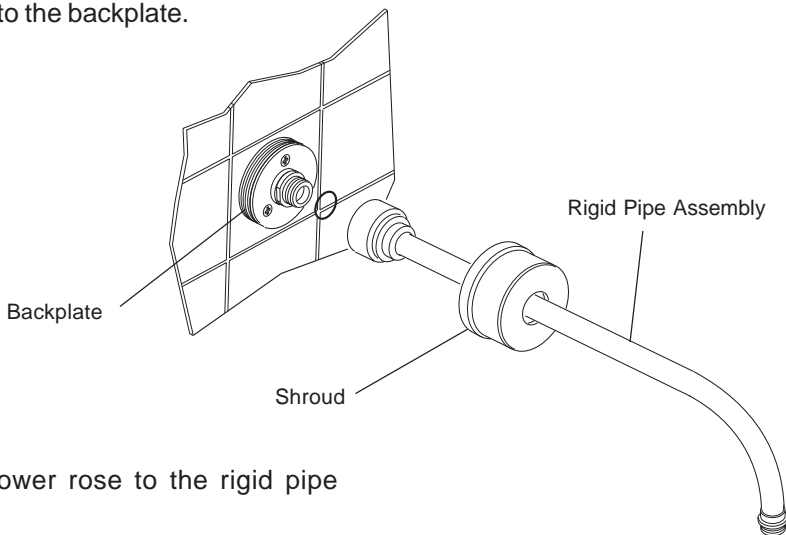

5. Fit the shower rose to the rigid pipe assembly.

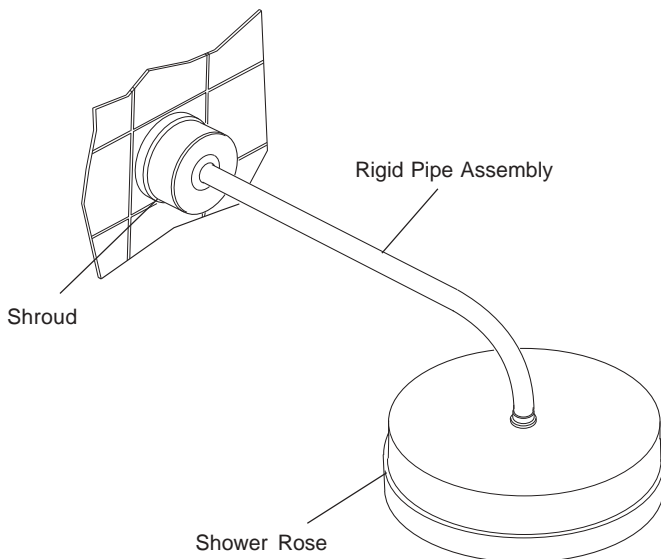

# COMMISSIONING

Commissioning must be carried out in accordance with these instructions, and must be conducted by designated, qualified and competent personnel.

## Maximum Temperature

The maximum blend temperature obtainable by the user should be limited, to prevent accidental selection of a temperature that is too hot.

All Mira Thermostatic mixing valves are fully performance tested and the maximum temperature is preset to approximately 42°C under ideal installation conditions at the factory. Site conditions and personal preference may dictate that the maximum temperature has to be reset following installation.

**Note!** An adequate supply of hot water at least 10°C above the required temperature must be available for correct operation of the shower control

1. Loosen grub screw in the shower control lever with 2.5 mm hexagon key supplied.
2. Turn shower control anticlockwise to maximum setting, Let temperature stabilise.
3. Remove shower control lever completely.
4. Insert the 2.5 mm hexagon key into the centre of valve head.
5. Turn the hexagon key **anticlockwise to increase** the temperature, or **clockwise to decrease** temperature.
6. Refit shower control lever and turn off mixer.
7. Tighten grub screw in the shower control lever.

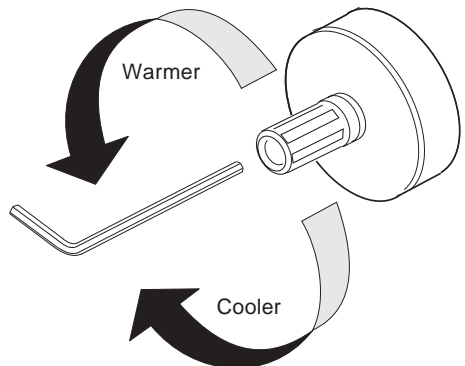
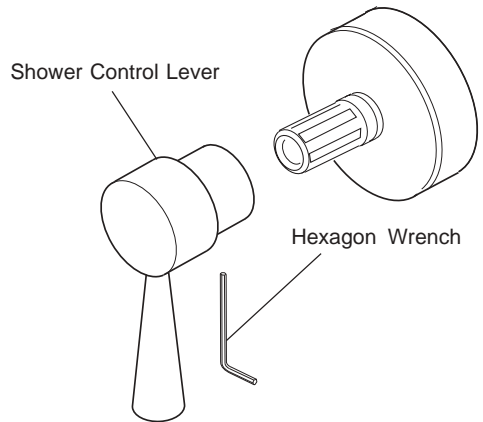

# OPERATION

## Temperature Selection (Exposed/Recessed Models)

The shower valve has one control to set temperature and works in a sequence:

Off # Cold # Tepid \$ # Pre-set Maximum

**Note!** The shower performance may be degraded if other water appliances are operated whilst the shower is in use.

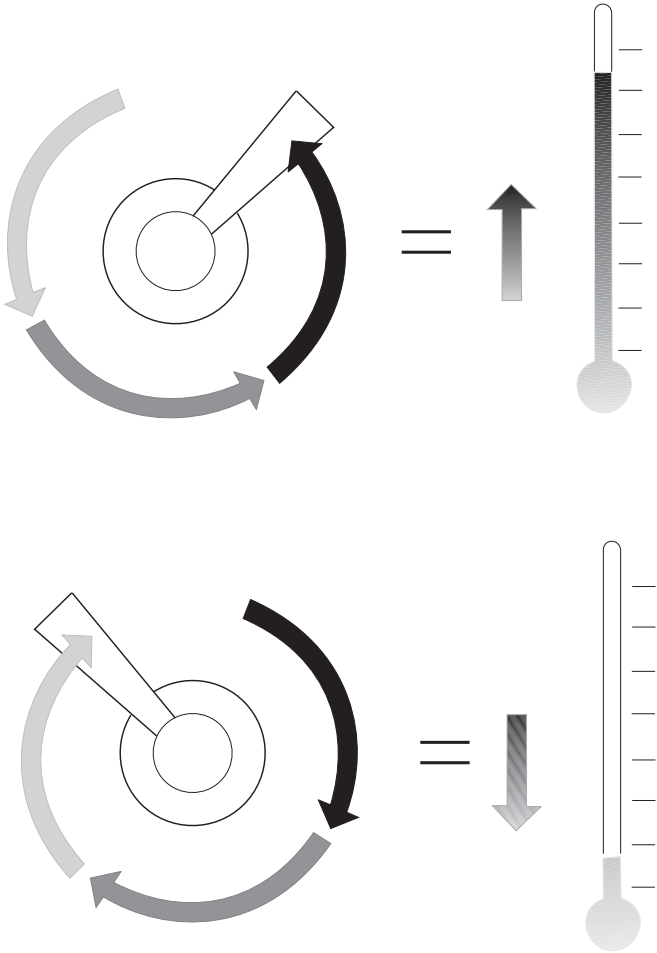

# FAULT DIAGNOSIS

<b>Symptom</b>	<b>Cause/Rectification</b>
<p><b>1.</b> Only hot or cold water from mixer outlet.</p>	<p>a. Inlets reversed (hot supply to cold supply).</p> <p>b. No hot water reaching mixer.</p> <p>c. Check fittings for blockage.</p> <p>d. Installation conditions continuously outside operating parameters: refer to <b>SPECIFICATION</b>, and <b>COMMISSIONING</b>.</p>
<p><b>2.</b> Fluctuating or reduced flow rate.</p>	<p>a. Check fittings for blockage.</p> <p>b. Make sure minimum flow rate is sufficient for supply conditions.</p> <p>c. Make sure the maintained inlet pressures are nominally balanced and sufficient.</p> <p>d. Make sure the inlet temperature differentials are sufficient.</p> <p>e. Check thermostatic performance.</p> <p>f. Flow regulators fitted incorrectly.</p> <p>g. Airlock or partial blockage in pipework.</p>
<p><b>3.</b> No flow rate from mixer outlet.</p>	<p>a. Check fittings for blockage.</p> <p>b. Hot or cold supply failure.</p>
<p><b>4.</b> Blend temperature drift.</p>	<p>a. Refer to symptom <b>2.</b> above.</p> <p>b. Hot supply temperature fluctuation.</p> <p>c. Supply pressures fluctuating.</p> <p>d. Seal damage or wear. Renew seals.</p>
<p><b>5.</b> Maximum blend temperature setting too hot or too cold.</p>	<p>a. Indicates incorrect maximum temperature setting; refer to <b>COMMISSIONING</b> section.</p> <p>b. Refer to symptom <b>4.</b> above.</p>
<p><b>6.</b> Water leaking from Mixer Shower.</p> <p>Shower Fitting.</p>	<p>a. Obtain Seal Kit, renew all seals.</p> <p>b. Renew shut off head assembly.</p> <p>a. Renew shut off head assembly.</p>
<p><b>7.</b> Flow rate too low or too high.</p>	<p>a. (Too low) Insufficient supply pressures.</p> <p>b. (Too low) Refer to symptom <b>2.</b> above.</p> <p>c. (Too high) Supply pressure too high.</p> <p>d. (Too high) Refer to symptom <b>2.</b> above.</p>

# MAINTENANCE

## General

Mira products are precision-engineered and should give continued superior and safe performance, provided:

1. They are installed, commissioned, operated and maintained in accordance with the recommendations stated in this Product Manual.
2. Periodic attention is given as necessary to maintain the product and its associated installation components in good functional order.

## Cleaning

Many household cleaners contain abrasives and chemical substances, and should not be used for cleaning plated or plastic fittings. These finishes should be cleaned with a mild washing up detergent or soap solution, and then wiped dry using a soft cloth.

## Lubricants

**Important: Use silicone-only based lubricants on this product. Do not use oil-based or other lubricant types as these may cause rapid deterioration of seals.**

Standard silicone-only based lubricants may be used on all static seals, and threads, to assist refitting (e.g. Rocol MX22).

# SPARE PARTS

## Mira Mode Spare Parts List

SPHD0013J	Head Assembly
SPEL0003J	Element
SPSL0003J	Sleeve Assembly
SPSK0043J	Seal Kit - components identified 'A'
441 29	Lever Assembly
441 30	Shield Assembly
441 31	Screw Pack - components identified 'B'
441 32	Elbow Assembly
441 33	Outlet Assembly
441 34	Outlet Plug Assembly
441 35	Regulator Set
441 36	Backplate

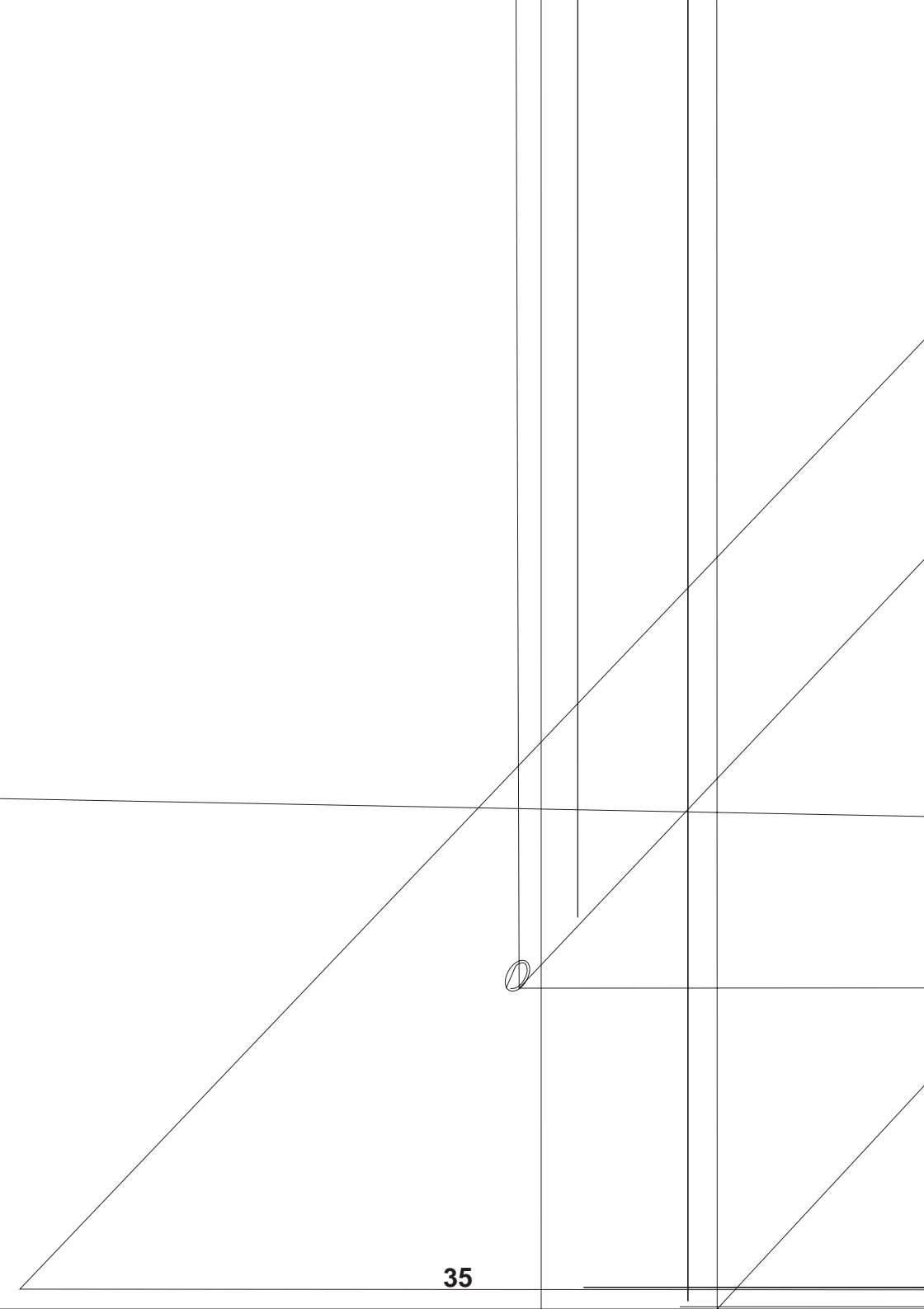

# Shower Fittings Spare Parts List

- 441 31 Screw Pack - components identified 'B'
- 441 37 Riser Assembly
- 441 38 Riser Bracket Assembly
- 441 39 8" Rose

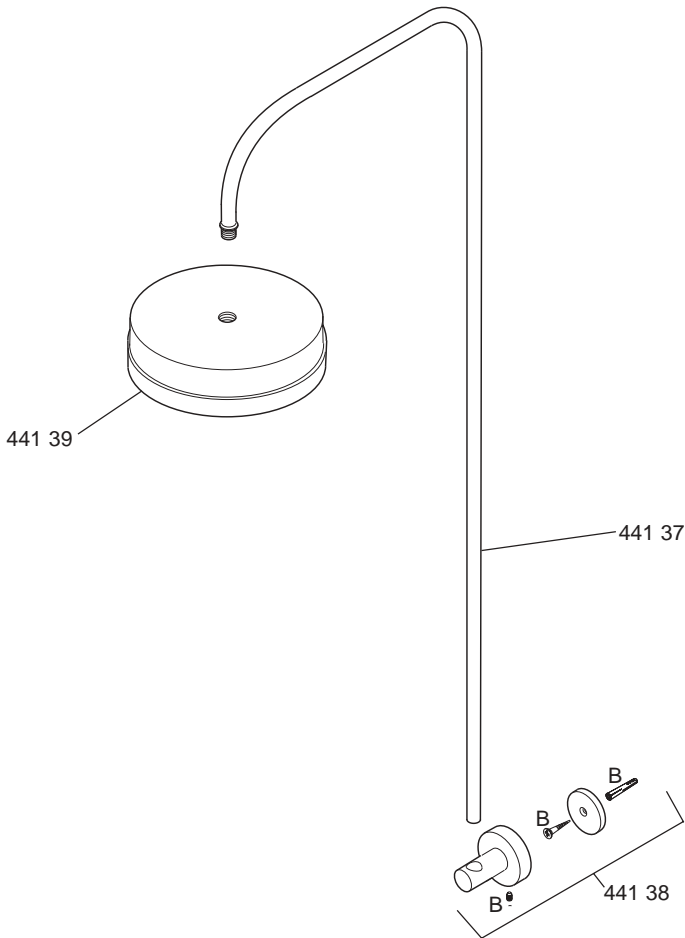

## Mira Mode B Spare Parts List

441 29	Lever Assembly
441 31	Screw Pack - components identified 'B'
441 36	Backplate
441 39	8" Rose
441 40	Shield Assembly
441 41	Plate Seals
441 42	Concealing Plate
441 43	Adaptor
441 44	Wall Bracket
441 45	Inlet/Outlet Connector
441 46	Backplate Assembly
441 47	Shroud
441 48	Rigid Pipe Assembly

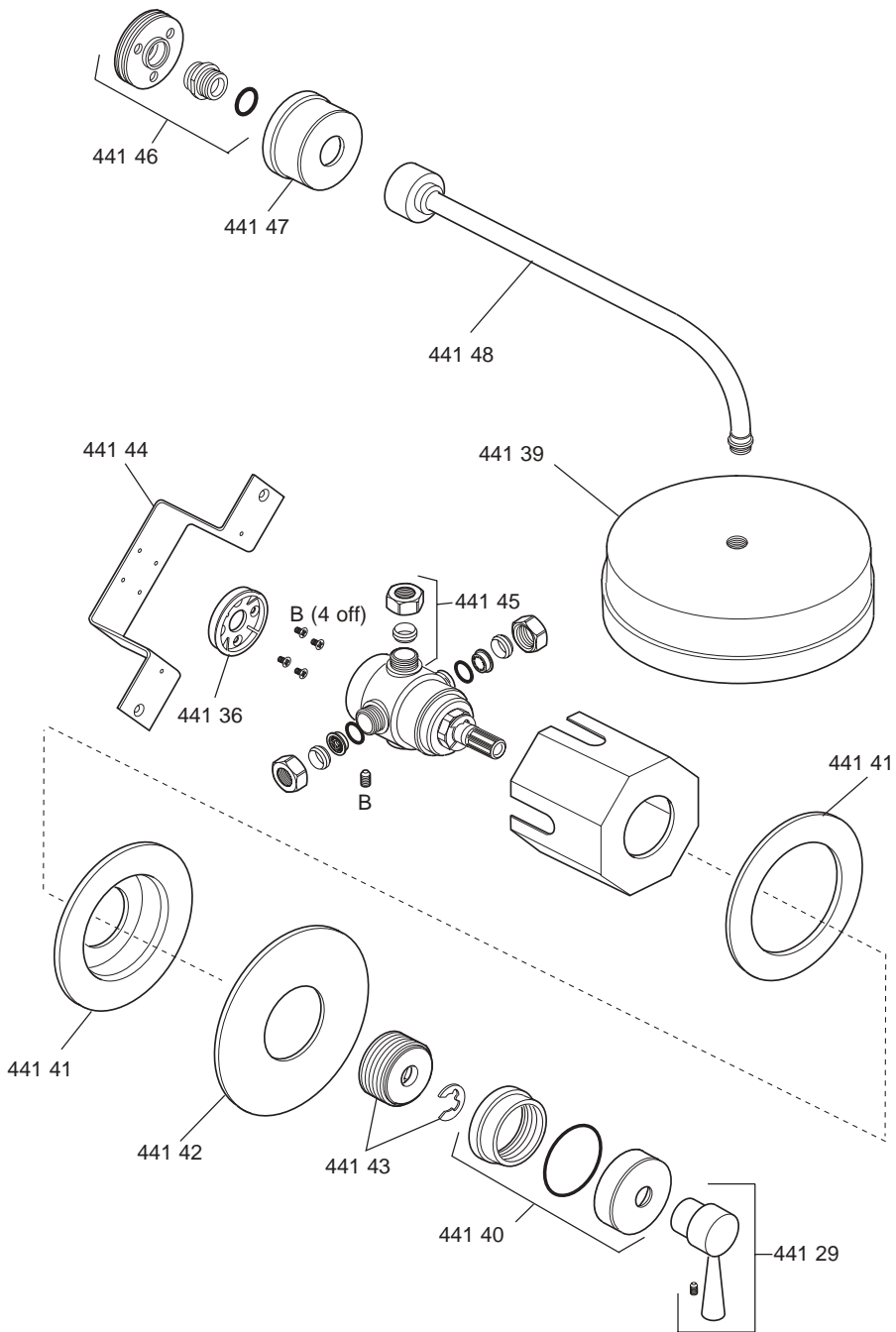

# NOTES

# Customer Service

Mira Showers guarantee products against any defect of materials or workmanship for one year from the date of purchase (2 years for Mira Select and 3 years for Mira Excel ranges).

**To validate the guarantee, please return your completed registration card.**

Within the guarantee period we will resolve defects, free of charge, by repairing or replacing parts or modules as we may choose.

To be free of charge, service work must only be undertaken by Mira Showers or our approved agents in Northern Ireland and Republic of Ireland.

**Service under this guarantee does not affect the expiry date. The guarantee on any exchanged parts or product ends when the normal product guarantee period expires.**

**Not covered by this guarantee:**

Damage or defects arising from incorrect installation, improper use or lack of maintenance, including build-up of limescale.

Damage or defects if the product is taken apart, repaired or modified by any person not authorised by Mira Showers or our approved agents.

**This guarantee is in addition to your statutory and other legal rights.**

## Before using your shower

Please take the time to read and understand the operating and safety instructions detailed in this manual.

## What to do if something goes wrong

If when you first use your shower it doesn't function correctly, first contact your installer to check that installation and commissioning are satisfactory and in accordance with the instructions in this manual. We are on-hand to offer you or your installer any advice you may need.

Should this not resolve the difficulty, simply contact our Customer Services who will give every assistance, and if necessary arrange for our service engineer to visit.

If later the performance of your shower declines, consult this manual to see whether simple home maintenance is required. Please call our Customer Services to talk the difficulty through, request service under guarantee if applicable, or take advantage of our comprehensive After-Sales service.

**As part of our quality and training programme calls may be recorded or monitored**

## Mira Showers

Kohler Mira Ltd  
Cromwell Road,  
Cheltenham GL52 5EP.

Mira is a registered trade mark.  
The company reserves the right to alter product specifications without notice.

[www.mirashowers.com](http://www.mirashowers.com)



BS EN ISO 9001 : 1994  
Reg. No. FM 14648

**mira**  
SHOWERS

Our Customer Services Team is comprehensively trained to provide every assistance you may need: help and advice, spare parts or a service visit.

## Spare Parts

We maintain an extensive stock of spares, and aim to have functional parts available for ten years from the date of final manufacture of the product.

Spares can be purchased from approved stockists or merchants (locations on request) or direct from Customer Services.

Spares direct will normally be despatched within two working days. Payment can be made by Visa or Access at the time of ordering. Should payment by cheque be preferred a pro-forma invoice will be sent.

Note! In the interests of safety, spares requiring exposure to mains voltages can only be sent to competent persons.

## Service

Our Service Force is available to provide a quality service at a reasonable cost. You will have the assurance of a Mira trained engineer/agent, genuine Mira spares – and a 12 month guarantee on the repair.

Payment should be made directly to the Service Engineer/ Agent, using Visa, Access or a cheque supported by a banker's card.

## To contact us:

England, Scotland & Wales

### Mira Showers Customer Services

Telephone: 01242 262888  
8.30am to 5pm Working days (4.30pm Fri)  
8.30 am to 12.30pm Saturday  
E-mail: [Mira\\_technical@mirashowers.com](mailto:Mira_technical@mirashowers.com)  
Fax: 01242 282595  
By Post: Cromwell Road  
Cheltenham  
Gloucester GL52 5EP

For Customers in Northern Ireland

### Wm H Leech & Son Ltd

Telephone: 028 9044 9257 – Mon to Fri 9 am-5pm  
Fax: 028 9044 9234 – 24 hours  
Post: Maryland Industrial Estate  
Ballygowan Road  
Moneyreagh, Co Down  
BT23 6BL

For Customers in Republic of Ireland

### Modern Plant Ltd

Telephone: Dublin 01 4591344 - Mon to Fri 9am to 5pm  
Fax: Dublin 01 4592329 – 24 hours  
Post: Otter House  
Naas Road  
Clondalkin  
Dublin 22