

unichrome

TRITON

AIRE • NENE • TYNE

bar mixer showers – thermostatic



EXE

bar mixer shower – pressure compensating



**Installation
and
Operating
Instructions**

INSTALLERS PLEASE NOTE THESE INSTRUCTIONS ARE TO BE LEFT WITH THE USER

<i>CONTENTS</i>	<i>Page</i>
Introduction	1
Safety warnings	1
Main components	2
Site requirements	3
Typical installations	4 - 5
Preparing the mixer valve	6
Siting of shower	6
Installation	7 - 8
Commissioning	8 - 9
Operating the shower	9
Cleaning the filters	9
Fitting the riser rail (Tyne)	10 - 11
Fitting the riser rail (Aire,Exe & Nene)	12
Sprayhead (Tyne) adjusting & cleaning	13
Sprayhead (Aire,Exe & Nene) adjusting & cleaning	14
Spare parts	15
Fault finding	16 - 17
Guarantee, service policy, etc.	rear cover

INTRODUCTION

This book contains all the necessary fitting and operating instructions for either your Triton **Aire**, **Nene** or **Tyne** bar mixer thermostatic shower or **Exe** pressure compensating bar mixer shower. Please read the instructions carefully. Read through the whole of this book before beginning your installation.

Note: If you have purchased the **Exe** shower please be aware that it is NOT thermostatic and will not prevent water from flowing from the sprayhead should there be a loss of one supply to the mixer.

The shower installation must be carried out by a suitably competent person and in sequence of this instruction book.

Care taken during the installation will ensure a long and trouble free life from your shower.

For optimum performance within the specified running pressure range a minimum flow of eight litres per minute should be available to both inlets.

The mixer shower MUST NOT be subjected to water temperatures above 80°C.

The mixers are designed for use with traditional low pressure 'gravity' water systems, using a cold water cistern and hot water cylinder (the **Exe** model must use a pump if installed in a gravity fed system).

All the models are suitable for the higher pressure systems found in the UK up to a maximum of 5 bar running pressure.

Important: When installing this mixer with a combination boiler or multi-point, the supplied flow restrictor must be installed in the unit.

The mixers are suitable for fully modulating type combination boilers and multi-point hot water heaters. Also suitable for thermal storage, unvented systems and pumped gravity systems.

Important: Before installing with a gas instantaneous water heater, ensure it is capable of delivering hot water at a minimum switch-on flow rate of 3 litres per minute. At flow rates between 3 and 8 litres per minute, the appliance must be capable of

raising the water temperature to a minimum of 52°C. Water temperature at the inlet to the mixer must remain relatively constant when flowrate adjustments are made (refer to the water heater operating manual to confirm compatibility with this mixer shower).

These mixers are supplied with an integral single check valve and integral filter in each inlet. Inlet connections are to 15mm compression or 1/2" BSP female fittings (not supplied).

SAFETY WARNINGS

- a Layout and sizing of pipework must be such that when other services are used, pressures at the shower control inlets DO NOT fall below the recommended minimum.
- b DO NOT choose a position where the shower could become frozen.
- c DO NOT connect this mixer shower to any form of tap or fitting not recommended by the manufacturer.
- d The sprayhead must be regularly cleaned to remove scale and debris.
- e Conveniently situated service valves in each inlet supply must be fitted as an independent method of isolating the shower should maintenance or servicing be necessary.
- f If it is intended to operate the shower in areas of hard water (above 200 ppm temporary hardness), a scale inhibitor may have to be fitted. For advice on the Triton scale inhibitor, please contact Customer Service.
- g DO NOT operate the shower outside the guidelines as laid out in 'site requirements'.

Replacement parts can be ordered from Triton Customer Service. See 'spare parts' for details and part numbers.

Due to continuous improvement and updating, specification may be altered without prior notice.

MAIN COMPONENTS

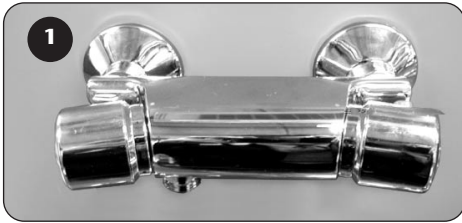

Aire

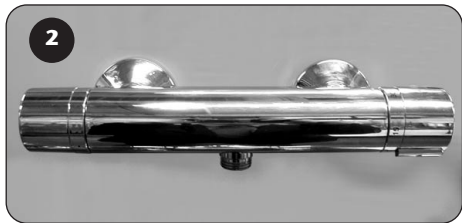

Nene

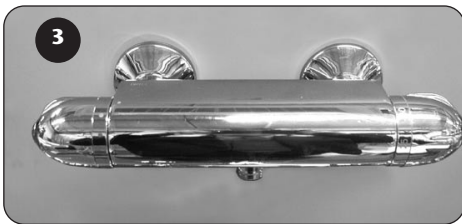

Tyne

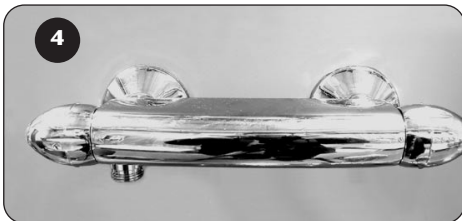

Exe

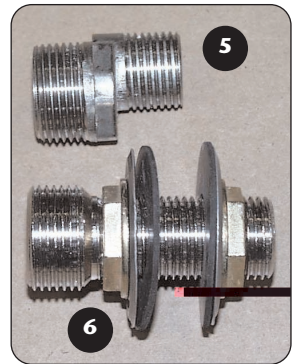

- 1 Mixer valve thermostatic – Aire
- 2 Mixer valve thermostatic – Nene
- 3 Mixer valve thermostatic – Tyne
- 4 Mixer valve pressure compensating – Exe
- 5 Offset inlet connector (Exe & Aire)
- 6 Straight inlet connector (Nene & Tyne)
 - Riser rail assembly (Tyne)
 - Riser rail assembly (std./economy)
 - Sprayhead (Tyne)
 - Sprayhead (std./economy)
 - Flow limiters

SITE REQUIREMENTS

The installation must be in accordance with Water Regulations and Byelaws.

Running water pressure:

Gravity fed

- Exe – 0.5 bar min. to 5 bar max.
- Aire – 0.2 bar min. to 5 bar max.
- Nene – 0.2 bar min. to 5 bar max.
- Tyne – 0.1 bar min. to 5 bar max.

Mains fed

all models – 1.0 bar min. to 5.0 bar max.

Maximum static water pressure:

Gravity and mains – 10 bar

DO NOT connect the mixer shower to a gravity hot supply and a mains cold supply (or vice versa).

For optimum performance within the specified running pressure range a minimum flow of eight litres per minute should be available to both inlets.

While the mixer shower is operational (open outlet), inlet pressures must not be capable of exceeding 7 bar. For effective operation of the internal seals, the maximum static pressure must not be exceeded.

Note: On sites where the running pressure is above 5 bar, the use of a suitably sized pressure reducing valve fitted in the cold mains supply pipework can provide nominally equal pressures at the shower mixer.

Note: The **Exe** shower is NOT thermostatic and will not prevent water from flowing from the sprayhead should there be a loss of one supply to the mixer.

The pipework should be installed such that the flow is not significantly affected by other taps and appliances being operated elsewhere on the premises.

Where thermal store systems and instantaneous gas water heaters are used, if excessive draw offs take place the boiler may not be able to maintain an adequate output temperature. This could result in the shower temperature becoming noticeably cooler.

Water temperature requirements

Maximum hot water temperature = 80°C

Recommended maximum = 65°C

Minimum hot water temperature = 52°C

Maximum cold water temperature = 20°C

BS 6700 recommends that the temperature of stored water should never exceed 65°C.

A stored water temperature of 60°C is considered sufficient to meet all normal requirements and will minimise the effects of scale in hard water areas.

Temperature adjustment range

The mixed water temperature can be adjusted from cold through to a top limit which can be pre-set during installation with full anti-scald protection throughout the range (35°C to 40°C) providing the hot water temperature at the inlet remains 10°C above the outlet temperature.

To ensure the product suitability for commercial and multiple installations, please contact Triton's specification advisory service prior to installation.

Telephone: (024) 7632 5491

Facsimile: (024) 7632 4564

E mail: technical@triton.plc.uk

Fig.2 (diagrammatic view – not to scale)

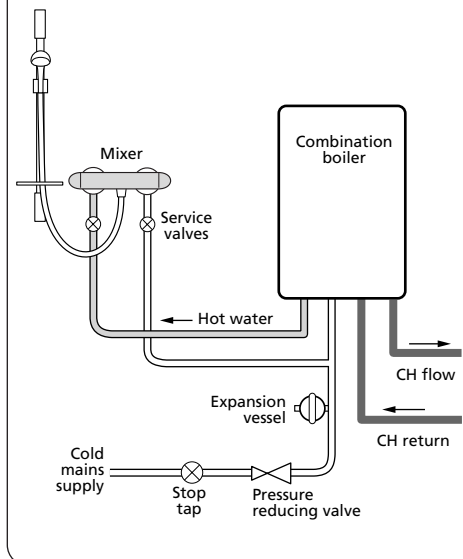

TYPICAL SUITABLE INSTALLATIONS

a) Instantaneous gas-heated systems, e.g. combination boilers (fig.2).

The shower control **MUST** be installed with a multipoint gas water heater or combination boiler of a fully modulating design (i.e. to maintain relatively stable hot water temperatures).

A drop tight pressure reducing valve **MUST** be fitted if the supply pressures exceed 5 bar running.

An expansion vessel (shown in **fig.2**) **MUST** be fitted, and regularly maintained, to ensure the shower mixer is not damaged by excess pressures. This may already be installed within the boiler (check with manufacturer) and is in addition to the normally larger central heating expansion vessel.

The layout and sizing of pipework **MUST** be such that nominally equal inlet supply pressures are achieved and the effects of other draw-offs are minimised. The hot supply temperature **MUST** remain a minimum of 10°C hotter than the required blend temperature for optimum performance.

b) Unvented mains pressure systems (fig.3).

The shower control can be installed with an unvented, stored hot water cylinder.

For systems with no cold water take off after the appliance reducing valve, it will be necessary to fit an additional drop tight pressure reducing valve when the mains pressure is over 5 bar. The drop tight pressure reducing valve must be set at the same value as the unvented package pressure reducing valve.

NOTE: An additional expansion vessel (**fig.3**) may be required if a second pressure reducing valve is installed. This does not apply to packages with a cold take off after the pressure reducing valve to the cylinder.

The layout and sizing of pipework **MUST** be such that nominally equal inlet supply pressures are achieved and the effects of other draw-offs are minimised.

Fig.3 (diagrammatic view – not to scale)

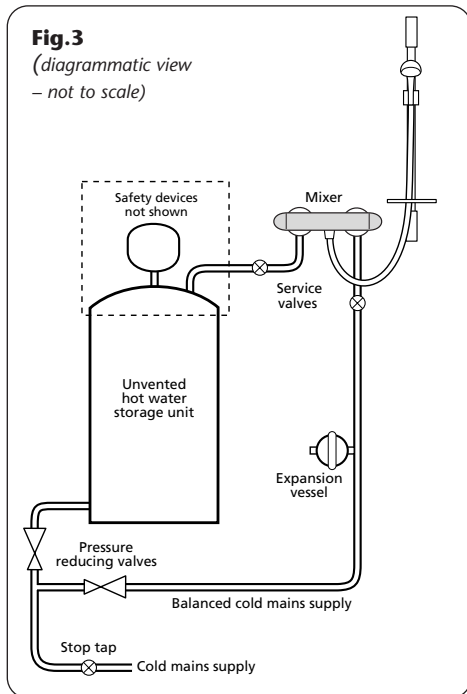

c) Mains pressurised thermal store systems (fig.4).

Packages of this type, fitted with a tempering valve (blender valve) can be used. A drop tight pressure reducing valve **MUST** be fitted if the supply pressures exceed 5 bar running.

An expansion vessel (shown in **fig.4**) **MUST** be fitted, and regularly maintained, to ensure the unit is not damaged by excess pressures. This may already be installed externally or internally within the thermal store (check with thermal store manufacturer).

d) Gravity fed systems (fig.5).

The shower control **MUST** be fed from a cold water cistern and hot water cylinder providing nominally equal pressures. There must be a minimum of between 1 and 5 metres head of water depending on the shower model. The minimum head distance is measured from the base of the cold water cistern to top of the shower head.

Note: If installing the **Exe** model on a gravity fed system, a pump must be fitted in the supply pipework to the valve.

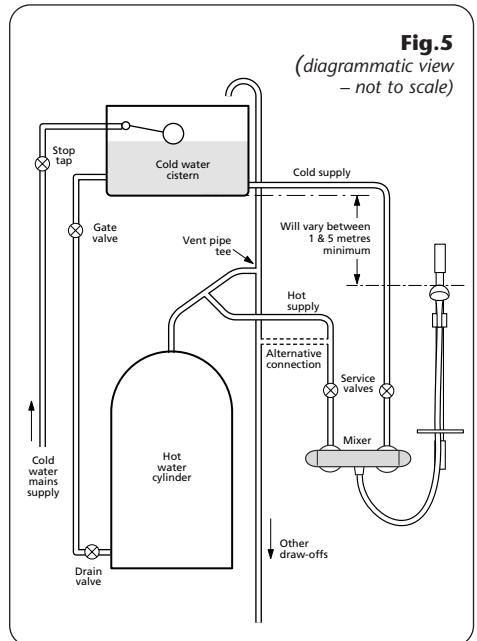
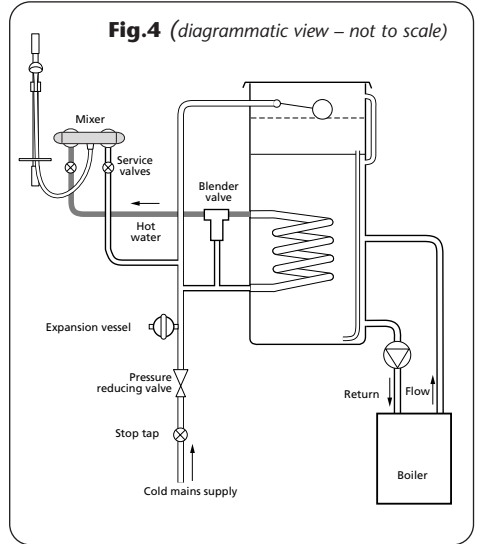
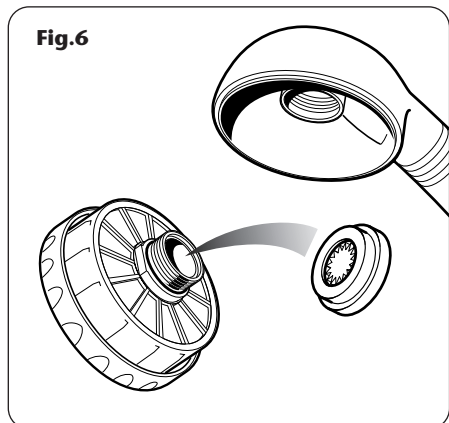

Fig.6



INSTANTANEOUS WATER HEATERS APPLIANCE CAPABILITIES

In order to ensure the optimum performance from the shower when connected to an instantaneous water heater, the appliance must be capable of raising the temperature of the incoming water to a minimum of 52°C (125°F) and delivering a flow rate of not less than eight litres per minute.

Flow limiters are supplied for controlling the maximum flow of eight litres per minute.

For the **Exe** and **Aire** units, a flow limiter is inserted into the sprayhead (**fig.6**) while the **Nene** and **Tyne** models have the flow limiters inserted into the long thread inlet fittings as follows:- Insert the filter, then the limiter and secure with the threaded retainer (**fig.7**).

With the flow limiters fitted and when the system is in use, the on/off flow control should be turned fully anti-clockwise to full flow setting.

Fig.7

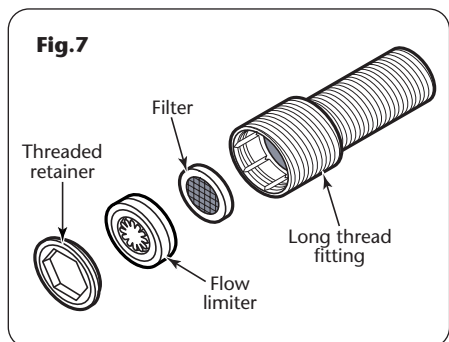

PREPARING THE MIXER VALVE

Check the contents to ensure all parts are present.

Before commencing the installation, make sure all the apertures on the valve are carefully covered to prevent ingress of any debris etc. while routing the supply pipework.

The shower valve is suitable for installation on a solid wall, a stud partition wall, dry lined wall or fixing to a laminate cubicle or panel.

The hot and cold water pipes should be securely attached within the wall or panel to support the valve and prevent movement after installation.

The hot water inlet has a red symbol adjacent to the inlet and must be on the left side.

SITING OF THE SHOWER

WARNING: THE SHOWER MUST NOT BE POSITIONED WHERE IT WILL BE SUBJECT TO FREEZING CONDITIONS.

Refer to **fig.8** for correct siting of the shower.

Position the shower and sprayhead on the wall so that all controls can be comfortably reached whilst using the shower. The sprayhead can be positioned either side of the shower.

The unit must be positioned horizontally with the outlet port at the bottom.

INSTALLATION

NOTE: The outlet of the shower must not be connected to anything other than the sprayhead supplied. DO NOT use jointing compounds on any pipe fittings for the installation. DO NOT solder fittings within the vicinity of the mixer unit as heat transfer can damage the seals and thermostatic components.

NOTE: Suitable service valves (complying with Water Regulations and Byelaws) MUST be fitted on the hot and cold water supplies to the shower as an independent means of isolating the water supplies should maintenance or servicing be necessary.

When connecting the pipework, avoid using tight 90° elbows. Swept or formed bends will ensure optimum performance.

Offset fittings

The supply pipes can be routed either from the side, rising, rear or falling and must terminate in standard 1/2" BSP female elbows (**fig.9**) to accept the offset fittings supplied.

The inlet centres on the shower valves are 150mm but with the offset fittings an additional 20mm adjustment is provided.

When installing into a stud partition or other hollow wall structures, the installer will need to consider fabricating rear supports or other options. Such options are beyond the scope of this guide.

The hot and cold supply pipes must be anchored rigidly in order to support the valve and prevent movement after installation.

The pipe depth must be such that the face of the elbow is flush with the finished surface.

Flush out the pipework in accordance with Water Regulations and Byelaws.

Screw the supplied offset fittings into the female elbows using PTFE thread tape, ensuring they are the correct centres for the shower valve.

Make good the wall, tiling etc. up to the outlets.

Screw the supplied collars onto the fittings until tight to the wall. The collars will provide a limited degree of tolerance and the amount of exposed thread will depend on the accuracy of elbows set in the wall.

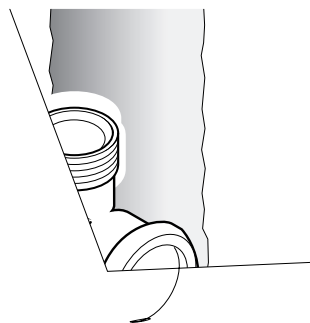
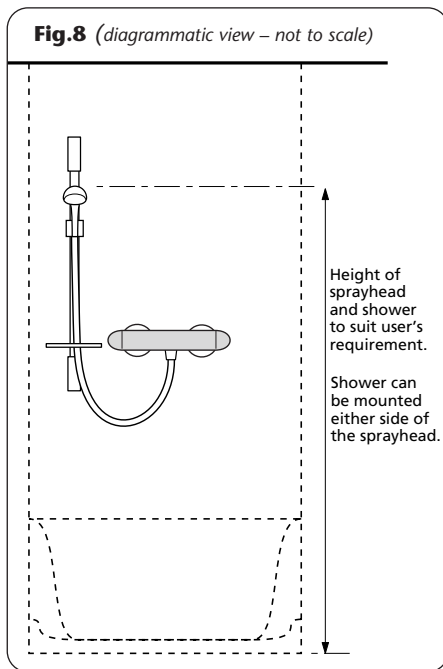

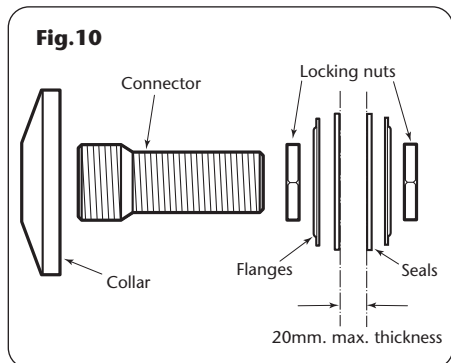

Offer the shower valve to the fittings and ensuring the sealing washers are place, screw the unions onto the fittings.

Straight fittings

The straight connectors can be used to connect to 1/2" BSP female elbow fittings in solid wall installations. The terminating outlet elbows must be aligned horizontally and centred to 150mm.

The hot and cold supply pipes must be anchored rigidly in order to support the valve and prevent movement after installation.

If installing in hollow walls or laminate cubicles, the fittings are supplied to compress onto the wall to support the shower valve (**fig. 10**).

The maximum thickness of wall is approx. 20mm. Sufficient room must be left on the fitting to accommodate the compression nut and olive. At the front end, allowance must be made to accept the shower union and collar.

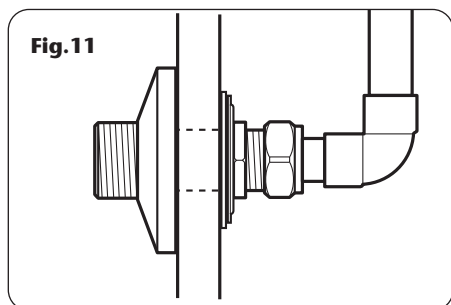

Flush out the pipework in accordance with Water Regulations and Byelaws.

Connect 15 mm pipes using standard compression nuts and olives (**fig. 11**).

Screw the supplied collars onto the fittings until tight to the wall.



Offer the shower valve to the fittings and ensuring the sealing washers are place, screw the unions onto the fittings. If installing with a combi multipoint system, ensure the flow limiters are fitted.

LEAK TESTING

Fit the hose to the outlet and direct it to waste. Open the supplies and test for leaks in the valve connections. Remedy any leaks if necessary.

COMMISSIONING

Ensure that both hot and cold water supplies are fully open and at (or near to) their design temperature and pressures and are within the requirements as stated.

Ensure the temperature knob (right side) is rotated fully anti-clockwise (press override button to achieve maximum temperature setting).

Ensure the sprayhead is directed to waste.

Start the water flow by turning the flow control (left side) anti-clockwise.

Allow the shower to run at the maximum temperature setting until the water temperature has stabilised. Using the temperature control knob, rotate until your desired maximum showering temperature is reached.

The mixer valve is fitted with a maximum temperature override button factory set at 40°C.

The mixer valve is factory set to provide a maximum outlet temperature of 40°C but this should be checked on site to ensure the setting has not been altered and also to ensure user safety.

To adjust the maximum temperature override setting.

When the showering temperature is satisfactory, remove the temperature control knob by removing the end cap and unscrewing the retaining screw (**fig.12**). (On the **Nene** unit, loosen the grub screw – **fig.13**). Re-position the control on the spline so the peg inside the control engages against the stop (**fig.14**) on the temperature control body. Refit the controls and secure with the screw/grub screw.

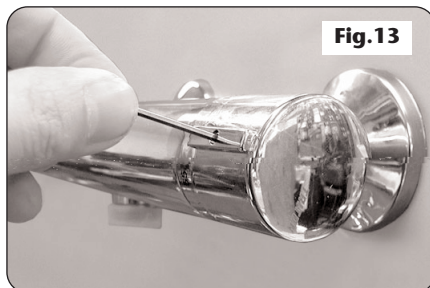

Fig.13

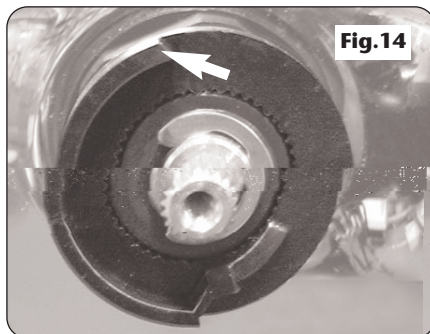

Fig.14

OPERATING THE SHOWER

To start the shower, rotate the on/off flow lever (left side) fully anti-clockwise for maximum flow.

To stop the water flow, rotate the on/off flow lever fully clockwise.

To adjust the water temperature, rotate the temperature control (right side) – clockwise for a cooler shower or anti-clockwise for a hotter shower.

To overcome the maximum temperature stop, depress the red button.

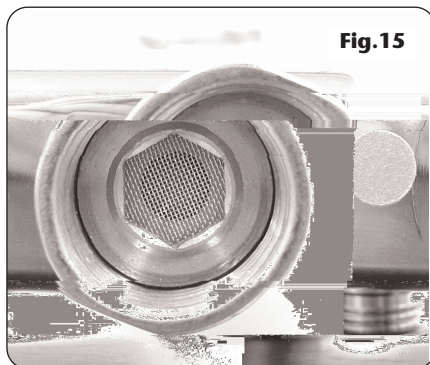

Fig.15

CLEANING THE FILTERS

Turn off the water supplies before proceeding.

To gain access to the filters will require the removal of the unit from the inlet fittings.

Note: On the **Nene** and **Tyne** models the filters are located before the flow limiters in straight connectors. Remove the flow limiters to gain access. Remove the sealing washers from the union inlets and unscrew the filter cap on each inlet (**fig.15**). Remove the filter and wash the filter thoroughly under running water to remove all debris. Replace the filter into the recess on the cap and screw the unit back into each inlet union.

Reassemble the shower to the inlet fittings.

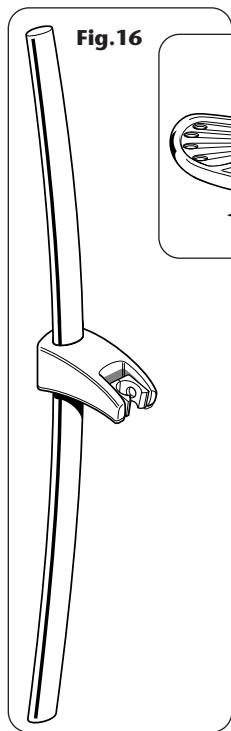

Fig. 16

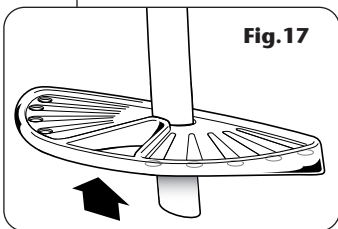

Fig. 17

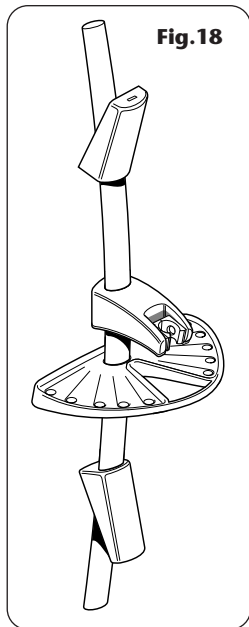

Fig. 18

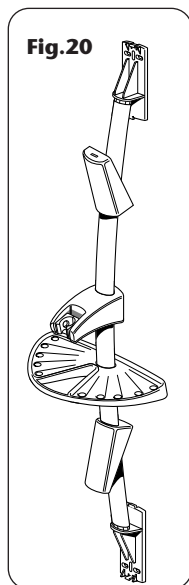

Fig. 20

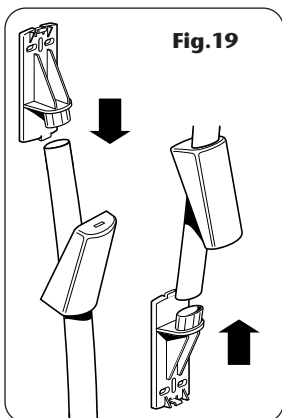

Fig. 19

FITTING THE RISER RAIL ASSEMBLY (Tyne)

WARNING: Check there are no hidden cables or pipes before drilling holes for wall plugs. Use great care when using power tools near water. The use of a residual current device (RCD) is recommended.

Decide the position for the rail on the wall within the shower area. Proceed as follows: The sprayhead holder is supplied already attached to the riser rail unit and the angle of the holder dictates the rail top and bottom. The correct orientation of the rail is when the sprayhead holder is sloping **DOWN (fig.16)**.

Slide the supplied soap dish onto the riser rail below the sprayhead holder **(fig.17)**.

Slide the top and bottom finishing trims onto the riser rail **(fig.18)**.

Push the two fixing brackets into the ends of the riser rail **(fig.19)**.

Offer the rail assembly to the wall **(fig.20)**. Using the brackets as templates, mark two upper holes and two lower holes. Note there are four provisions for screws per bracket – select the two most suitable for your requirements. Ensure the rail is aligned vertically.

Drill and plug the wall.

(The wallplugs provided are suitable for most brick walls – use an appropriate masonry drill, but if the wall is plasterboard or a soft building block, use special wallplugs and an appropriate drill bit obtainable from most hardware stores).

Screw to the wall with the fixing screws supplied.

Slide the finishing trims onto the brackets. Ensure the lug on each rail bracket end engages into the slot on the fatter end of each trim before push fitting the thinner ends in place (**fig.21**).

To remove a trim, push a small screwdriver or similar through the slot in the trim end and carefully pull away from the wall bracket.

Slide the soap dish down the rail so that its bracket engages on top of the lower finishing trim.

Adjusting the sprayhead holder

The holder is supplied already attached to the rail unit. To adjust the height, press the button underneath the holder to release the locking mechanism (**fig.22**). Still pressing the button, move the holder up or down to suit user's requirement.

Hose and sprayhead

Feed the flexible hose through the appropriate soap dish aperture (**fig.23**) so the dish acts as a retaining ring (Water Regulations).

Screw the flexible hose to the shower outlet and sprayhead ensuring the supplied washers are in place at both ends of the flexible hose (**fig.24**).

Place the sprayhead into the holder and check that it fits correctly (**fig.25**).

NOTE: The holder is slightly tapered and the sprayhead and hose will only fit from one direction.

Important: It is the conical end of the hose which grips into the holder. The sprayhead will not fit in the holder without the hose attached.

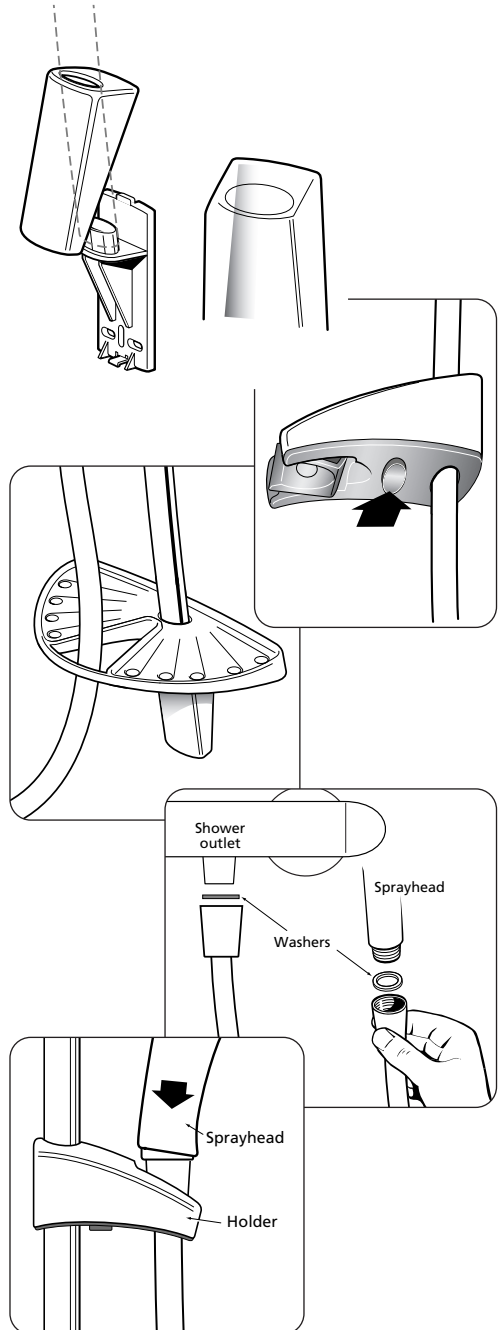

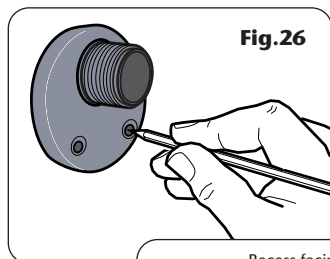

Fig. 26

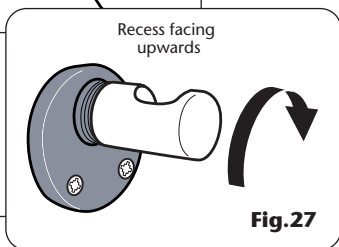

Fig. 27

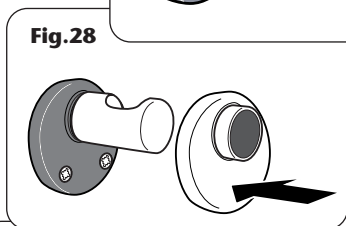

Fig. 28

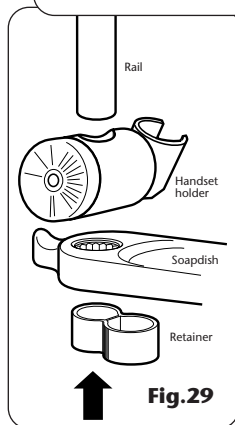

Fig. 29

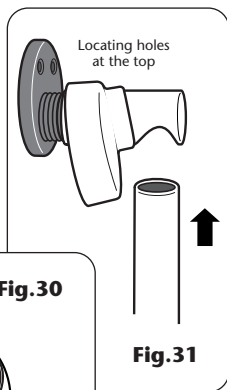

Fig. 31

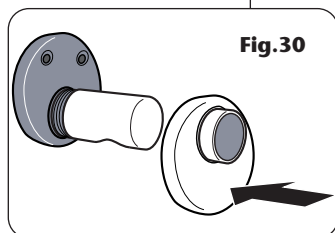

Fig. 30

FITTING THE RISER RAIL ASSEMBLY (Aire, Exe and Nene)

WARNING: Check there are no hidden cables or pipes before drilling holes for wall plugs. Use great care when using power tools near water. The use of a residual current device (RCD) is recommended.

Decide on the position of the rail on the wall within the shower area. Proceed as follows:
Offer one of the two brackets to the wall for the lower position only. Using the bracket as a template mark the location of the holes (fig. 26). Drill and plug the wall. Replace the bracket to the wall and secure with the screws supplied.

Screw the lower rail support onto the bracket, ensuring that the recess faces upwards (fig. 27). Note that the lower support DOES NOT have a locating pin in the recess. Push the bracket cover into place over the bracket and support (fig. 28).

Fit the handset holder, soap dish and hose retainer onto the rail (fig. 29). When fitting, note that the rail has a notch in the top.

Screw the top support into the top bracket and then slide the cover over the support but do not push the cover onto the bracket (fig. 30).

Fit the top support and cover onto the rail, ensuring that the notch correctly aligned (fig. 31).

Fit the rail onto the installed lower support. Ensure the rail is vertical and the top bracket positioned correctly. Mark the position of the holes. Remove the rail assembly. Drill and plug the wall. Refit the rail assembly to the lower support and secure the top bracket using the screws supplied.

Push the cover into position over the bracket.

Feed the flexible hose through the retainer so it acts as a retaining ring (Water Regulations).

Screw the flexible hose to the shower outlet and sprayhead ensuring the supplied washers are in place at both ends of the flexible hose.

Fig.32

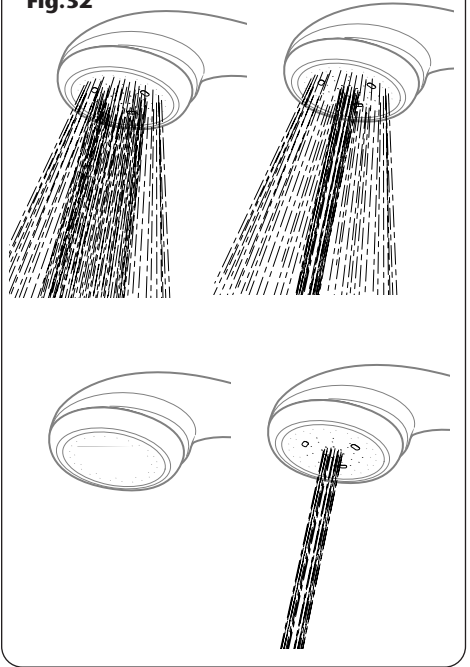

Fig.33

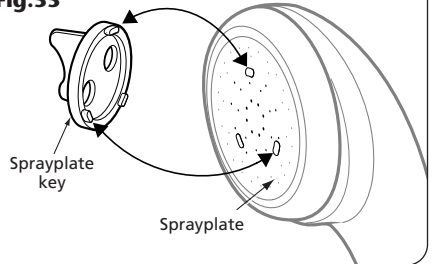

Fig.34

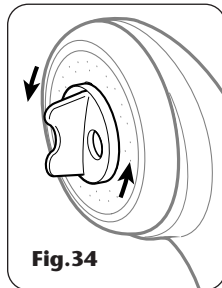

Fig.35

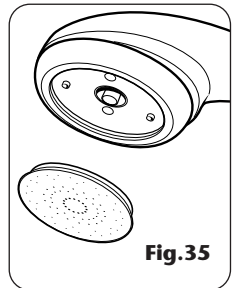
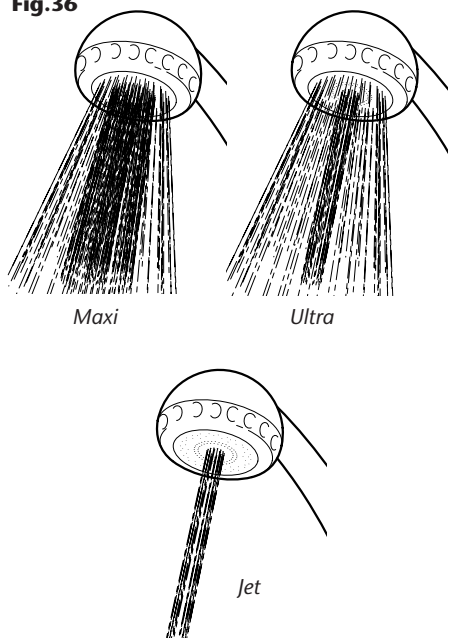

Fig.36



ADJUSTING THE SPRAYHEAD (Aire, Exe and Nene)

Three sprayhead patterns are available (**fig.36**). Adjustment is by turning the bezel on the sprayhead in either direction until the desired pattern is obtained.

MAXI

A full spray perfect for a relaxing shower.

ULTRA

A focused spray for a refreshing, satisfying shower.

JET

A concentrated spray for an exhilarating shower.

CLEANING

Do not use abrasive or solvent cleaning fluids. The shower unit, riser rail, hose, etc. should be cleaned using a soft cloth and warm water.

It is advised before cleaning, to turn the isolation switch off, thus avoiding the shower being accidentally switched on.

IT IS IMPORTANT TO KEEP THE SPRAYHEAD CLEAN TO MAINTAIN THE PERFORMANCE OF THE SHOWER. The hardness of the water will determine the frequency of cleaning. For example, if the shower is used every day in a very hard water area, it may be necessary to clean the sprayhead on a weekly basis.

Sprayhead removal procedure

Remove the sprayhead from the hose. Remove the sprayhead cartridge (**fig.37**) by turning the bezel anti-clockwise until a 'stop' is felt. Overcome the 'stop' by continuing to turn anti-clockwise until the cartridge and bezel come out.

Clean the cartridge with a suitable brush or preferably leave to soak overnight in a mild proprietary descaler. Ensure all traces of scale are removed and thoroughly rinse in clean water afterwards.

Refit the cartridge by screwing in clockwise until tight and replace the sprayhead on the hose.

Fig.37

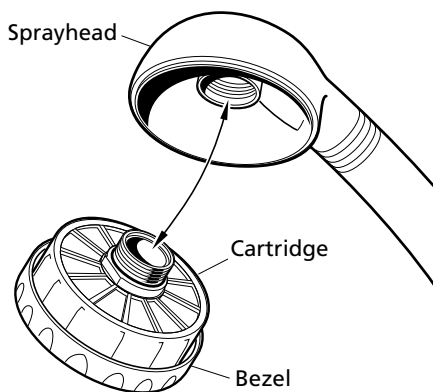

Ref. Description **Part No.**

1	Closure knob Exe Aire Nene Tyne	83307390 83307310 83307440 83307490
2	Mechanic headwork	83307320
3	Thermostatic body Exe Aire Nene Tyne	83307400 83307330 83307450 83307600
4	Thermostatic cartridge Exe Aire Nene Tyne	83307410 83307340 83307460 83307500
5	Regulation knob Exe Aire Nene Tyne	83307420 83307350 83307470 83307510
6	Straight inlet connector (Nene)	83307430
6	Straight inlet connector (Tyne)	83307480
7	Non-return valve	83307290
7	Non-return valve (Exe) Offset inlet connector (Aire & Exe)	83307370 8330728
8	Nut	83307300
8	Nut (Exe)	83307380
9	Outlet connection	83307360

Luxury riser rail

10	Brackets (pr.)	22010430
11	Trims (pr.) – chrome	22010740
12	Riser rail – chrome	22010750
13	Sprayhead holder – chrome	22010730
14	Soap dish	22010470
15	4 mode sprayhead – chrome	22410040

Standard/economy riser rail

16	Trims and brackets	22010770
17	Riser rail	22010780
18	Sprayhead holder	22010760
19	3 mode sprayhead – chrome	22010680
20	Hose retainer	22010790
-	Soap dish	22010800
-	Flow limiter (green 7 litre)	22003530
-	Flow limiter (white 8 litre)	22009590

SPARE PARTS

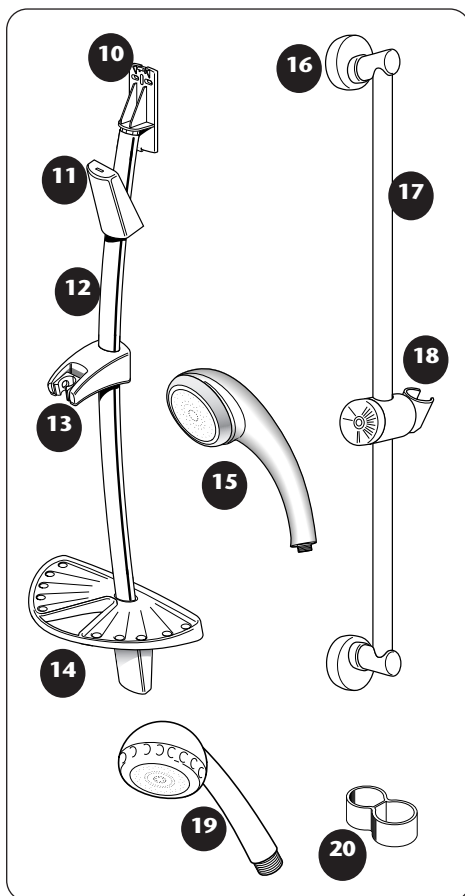
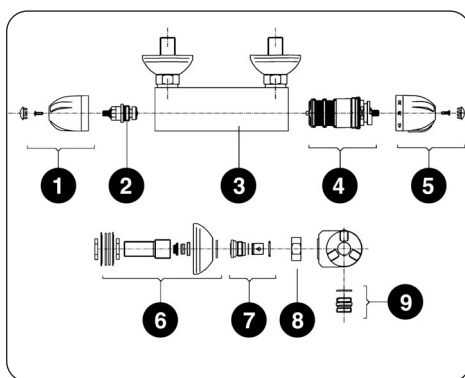

FAULT FINDING

The following can be carried out by a competent person

<i>Problem/Symptom</i>	<i>Cause</i>	<i>Action/Cure</i>
1 Water too hot.	<p>1.1 Temperature control incorrectly commissioned.</p> <p>1.2 Not enough cold water flowing through shower.</p> <p>1.3 Increase in the ambient cold water temperature.</p> <p>1.4 Cold water supply blocked.</p> <p>1.5 High volume of cold water drawn off elsewhere.</p>	<p>1.1.1 Refer to commissioning section.</p> <p>1.2.1 Turn temperature control anti-clockwise.</p> <p>1.3.1 Turn temperature control anti-clockwise.</p> <p>1.4.1 Turn shower off and consult a competent plumber or contact Triton Customer Service.</p> <p>1.5.1 Reduce the simultaneous demand from the supply.</p>
2 Water too cold	<p>2.1 Temperature control incorrectly commissioned.</p> <p>2.2 Not enough hot water flowing through shower.</p> <p>2.3 Decrease in the ambient cold water temperature.</p> <p>2.4 Insufficient hot water supplies from the heating system.</p> <p>2.5 Hot water supply blocked or restricted.</p> <p>2.6 Flow limiter not fitted (HP systems only).</p>	<p>2.1.1 Refer to commissioning section.</p> <p>2.2.1 Turn the temperature control clockwise.</p> <p>2.3.1 Turn the temperature control clockwise.</p> <p>2.4.1 Ensure heating appliance is set to maximum or has sufficient stored hot water.</p> <p>2.4.2 Ensure heating appliance is igniting by trying a hot water tap elsewhere.</p> <p>2.5.1 Turn shower off and consult a competent plumber or contact Triton Customer Service.</p> <p>2.6.1 Fit the supplied flow limiter in the sprayhead (see 'instantaneous gas water heaters').</p>
3 High water flow and/or poor performance on a mains fed system.	<p>3.1 Flow limiters not fitted.</p>	<p>3.1.1 Fit the supplied limiter in the showerhead or inlets depending upon model (see 'high pressure systems').</p>
4 Water does not flow or shower pattern collapses when another outlet is turned on.	<p>4.1 Water supplies cut off.</p> <p>4.2 Shower unit blocked.</p> <p>4.3 Blockage in pipework.</p> <p>4.4 Sprayhead blocked.</p> <p>4.5 System not capable of supplying multiple outlets at the same time.</p>	<p>4.1.1 Check water elsewhere in house and if necessary contact local water company.</p> <p>4.2.1 Inspect the inlet filters. Clean if necessary.</p> <p>4.3.1 Turn the shower off and consult a suitably competent plumber.</p> <p>4.4.1 Clean sprayhead.</p> <p>4.5.1 Reduce the simultaneous demand.</p> <p>4.5.2 Ensure stop/service valves are fully open.</p> <p>4.5.3 Check if sufficient water pressure.</p>

FAULT FINDING**The following is recommended for a professional qualified installer only**

<i>Problem/Symptom</i>	<i>Cause</i>	<i>Action/Cure</i>
5 Water too cold	5.1 Running pressure in excess of maximum recommended.	5.1.1 Fit a pressure reducing valve.
6 Shower controls noisy whilst in use.	6.1 Running pressure in excess of maximum recommended.	6.1.1 Fit a pressure reducing valve
7 Shower will not shut off	7.1 Flow control washer worn.	7.1.1 Renew flow control washer.

TRITON STANDARD GUARANTEE

Triton Plc guarantee this product against all mechanical defects arising from faulty workmanship or materials for a period of five years for domestic use only, from the date of purchase, provided that it has been installed by a competent person in full accordance with the installation and operating instructions.

Any part found to be defective during this guarantee period we undertake to repair or replace at our option without charge so long as it has been properly maintained and operated in accordance with the operating instructions, and has not been subject to misuse or damage.

This product must not be taken apart, modified or repaired except by a person authorised by Triton Plc. This guarantee applies only to products installed within the United Kingdom and does not apply to products used commercially.

This guarantee does not affect your statutory rights.

What is not covered:

1 Breakdown due to: *a)* use other than domestic use by you or your resident family; *b)* wilful act or

neglect; *c)* any malfunction resulting from the incorrect use or quality of gas or water or incorrect setting of controls; *d)* faulty installation.

2 Repair costs for damage caused by foreign objects or substances.

3 Total loss of the product due to non-availability of parts.

4 Compensation for loss of use of the product or consequential loss of any kind.

5 Call out charges where no fault has been found with the unit.

6 The cost of repair or replacement of sprayheads, hoses, riser rails and/or wall brackets, or any other accessories installed at the same time.

7 The cost of routine maintenance, adjustments, overhaul modifications or loss or damage arising therefrom, including the cost of repairing damage, breakdown, malfunction caused by corrosion, furring, pipe scaling, lime scale, system debris or frost.

Service Policy

In the event of a complaint occurring, the following procedure should be followed:

1 Telephone Customer Service on (024) 7637 2222 (08457 626591 in Scotland and in Northern Ireland), having available the model number and power rating of the product, together with the date of purchase.

2 Triton Customer Service will be able to confirm whether the fault can be rectified by either the provision of a replacement part or a site visit from a qualified Triton service engineer.

3 If a service call is required it will be booked and the date of call confirmed. In order to expedite your request, please have your postcode available when booking a service call.

4 It is essential that you or an appointed representative (who must be a person of 18 years of age or more) is present during the service engineer's visit and receipt of purchase is shown.

5 A charge will be made in the event of an aborted service call by you but not by us, or where a call under the terms of guarantee has been booked and the failure is not product related (i.e. scaling and furring, incorrect water pressure, installation faults).

6 If the product is no longer covered by the guarantee, a charge will be made for the site visit and for any parts supplied.

7 Service charges are based on the account being settled when work is complete, the engineer will then request payment for the invoice. If this is not made to the service engineer or settled within 10 working days, an administration charge will be added.

Replacement Parts Policy

Availability: It is the policy of Triton to maintain availability of parts for the current range of products for supply after the guarantee has expired. Stocks of spare parts will be maintained for the duration of the product's manufacture and for a period of five years thereafter.

In the event of a spare part not being available a substitute part will be supplied.

Payment: The following payment methods can be used to obtain spare parts:

1 By post, pre-payment of pro forma invoice by cheque or money order.

2 By telephone, quoting credit card (MasterCard or Visa) details.

3 By website order, www.tritonshowers.co.uk

Triton Plc, Shepperton Park, Caldwell Road,
Nuneaton, Warwickshire. CV11 4NR

Customer Service

☎ (024) 7637 2222

Scottish and Northern Ireland Customer Service

☎ 08457 626591

Trade Installer Hotline

☎ (024) 7632 5491

Fax: (024) 7632 4564

www.tritonshowers.co.uk

E mail: technical@triton.plc.uk