

ASPIRANTE

SORGENTE

Bath shower mixer (built-in)



Installation and operating instructions

INSTALLERS PLEASE NOTE THESE INSTRUCTIONS ARE TO BE LEFT WITH THE USER

Contents	Page
Introduction	1
Safety warnings	1
Key to main components	2
Site requirements	3
Installation	4
Building-in depth	4
Solid wall, hollow wall and panel mounting	5
Plumbing	5
Fitting the outlet pipework	6
Making good	6
Fitting the bulkhead	6
Fitting the hose and showerhead	7
Fitting the tap shelf	7
Commissioning	8
Operation	8
Cleaning	8
Spare parts	9
Fault finding	10 – 11
Guarantee, service policy, etc.	rear cover

To check the product suitability for commercial and multiple installations, please contact Triton's specification advisory service before installation.

Telephone: +44 (0) 24 7632 5491

Facsimile: +44 (0) 24 7632 4564

E mail: technical@triton.plc.uk

INTRODUCTION

This guide contains all the necessary fitting instructions for your Sorgente built-in bath shower mixer.

Please read this guide carefully before beginning your installation.

The mixer tap installation must be carried out by a suitably competent person and in the sequence specified in these instructions.

Care taken during the installation will give long life and trouble free operation from your mixer.

For the best performance within the specified running pressure range a minimum flow of 8 litres per minute should be available to both inlets.

DO NOT choose a position where the mixer could become frozen.

SAFETY WARNINGS

- a** Layout and sizing of pipework **MUST** be such that when other services are used, pressures at the inlets do not fall below the recommended minimum.
- b** **DO NOT** choose a position where the mixer tap could become frozen.
- c** Conveniently situated isolating valves in each inlet supply **MUST** be fitted as an independent method of isolating the mixer tap should maintenance or servicing be necessary.
- d** If it is intended to operate the shower in areas of hard water (above 200 ppm temporary hardness), a scale inhibitor may have to be fitted. For advice on the Triton scale inhibitor, please contact Customer Service.
- e** **DO NOT** operate the mixer outside the guidelines as laid out in 'site requirements'.

Replacement parts can be ordered from Triton Customer Service (*see back page*).

Due to continuous improvement and updating, specification may be altered without prior notice.

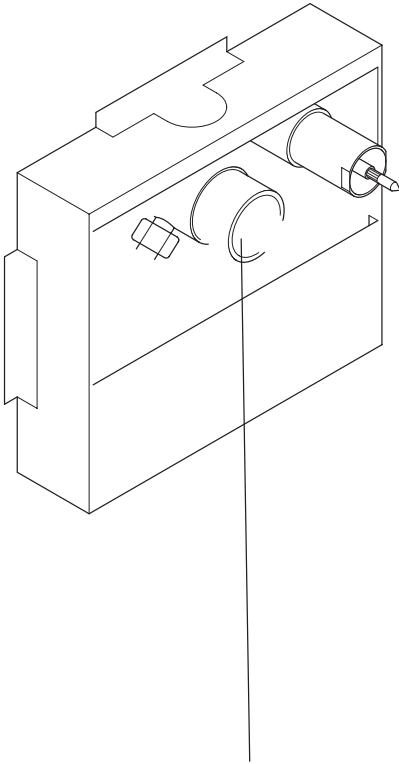

The bath shower mixer comprises the following items:

- 1.** Mounting plate and mixer valve
- 2.** Temperature control — hot
- 3.** Temperature control — cold
- 4.** Diverter control
- 5.** Tap shelf
- 6.** Retaining collar
- 7.** Cover trim
- 8.** Tap handle — hot
- 9.** Tap handle — cold
- 10.** Diverter control handle

Check that all parts are correct.

SITE REQUIREMENTS

This tap is suitable for high water pressures only and should be fitted in accordance with Water Regulations and Bylaws.

Running water pressure:

1 bar to 5 bar.

Maximum static water pressure

10 bar

For best performance within the specified pressure range a minimum flow of eight litres per minute should be available to both inlets.

While the shower is operating (open outlet), inlet pressures must not be capable of exceeding 7 bar. For effective operation of the internal seals, the maximum static pressure must not be exceeded.

Note: On sites where the running pressure is above 5 bar, the use of a suitably sized pressure reducing valve fitted in the cold mains supply pipework can provide nominally equal pressures at the mixer shower.

The pipework should be installed such that the flow is not significantly affected by other taps and appliances being operated elsewhere on the premises.

Note: The installation of this mixer will be greatly simplified if the incoming pipework enters from the bottom (rising).

Note: Where thermal store systems and instantaneous gas water heaters are used, if excessive draw-offs take place the boiler may not be able to maintain an adequate output temperature. This could result in the shower temperature becoming noticeably cooler.

Water temperature requirements

Maximum temperature — 85°C.

Recommended temperature — 60 to 65°C.

BS 6700 recommends that the temperature of stored water should never exceed 65°C.

A stored water temperature of 60°C is considered sufficient to meet all normal requirements and will minimise the effects of scale in hard water areas.

Note: For the ideal flow pattern it is advisable to install a pressure regulator in the inlet piping line to give 3 bar constant pressure.

INSTALLATION

WARNING!

The mixer must not be positioned where it will be subject to freezing conditions.

General conditions

DO NOT use jointing compounds on any pipe fittings for the installation.

DO NOT solder fittings near the mixer unit as heat can transfer along pipework and may damage seals and thermostatic components.

Note: Suitable isolating valves (complying with Water Regulations and Bylaws) MUST be fitted on the hot and cold water supplies to the shower as an independent means of isolating the water supplies should maintenance or servicing be necessary.

When connecting pipework avoid using tight 90° elbows. Swept or formed bends will give the best performance.

IMPORTANT: The water circuit should be installed such that the flow is not significantly affected by other taps and appliances being operated elsewhere on the premises. Water pressure must not fall below specification of the shower.

BUILDING-IN DEPTH

The allowance for varying thickness of tiles is accommodated by the tap shelf (**fig.2**). The tolerance between the tap shelf and the mounting box is 10 – 25mm.

The building-in depth is nominally given as 56mm (**fig.2**).

The following are typical thicknesses and are given as a guide only:

Tile	6 – 10mm
Adhesive	2 – 3mm
Plasterboard	9.5 – 12.5mm
Plaster finish	2 – 3mm

When installing into a stud partition or other hollow wall structure, the installer may wish to consider building rear supports or other options

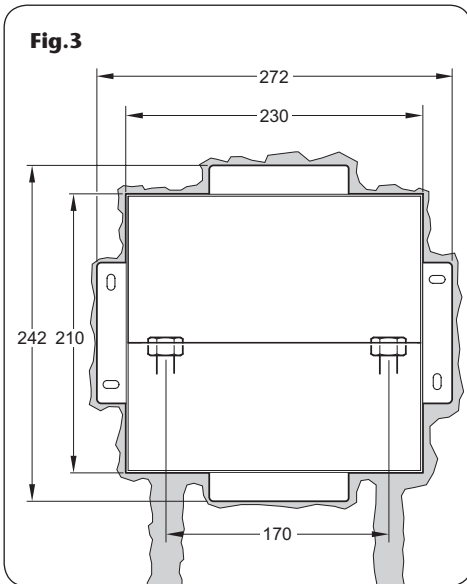
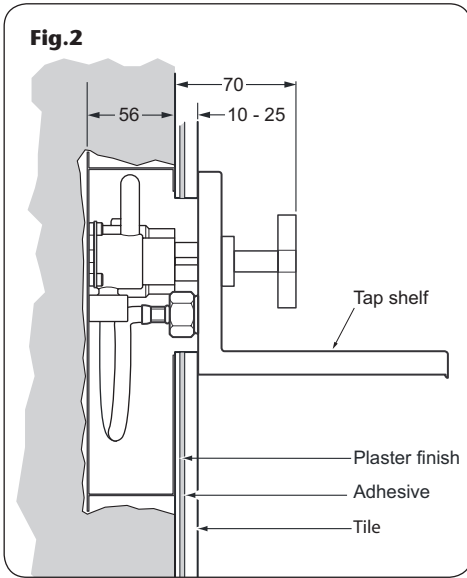

for fitting the mounting box. Such options are beyond the scope of this guide.

SOLID WALL, HOLLOW WALL AND PANEL MOUNTING

The building-in depth for the mounting box is typically 56mm from plaster finish but this is dependant upon tile and adhesive thicknesses.

Using the mounting box as a guide, mark the hole outline position onto the wall (**fig.3**). Remove the plaster and brickwork (or plasterboard) to the depth required and chase out any additional areas of wall to allow for the incoming and outgoing pipework.

The final separation between incoming pipe centres needs to be 170mm (**fig.3**).

Offer the mounting plate up to the wall. Centralise and mark the two holes.

Drill the wall and plug the holes.

Fit the mounting plate temporarily. Complete the pipework up to the mounting box and mark the pipework to enter the fittings.

Remove the mounting box and cut the pipework to length.

Note: It is preferable to flush the pipework (**fig.4**) to clear the system of debris and check for leaks before connecting to the mixer. This can be done by connecting a hose to the pipework and turning on the mains water supply long enough to clear the debris to waste.

Refit the mounting plate and secure in position.

PLUMBING

Using standard ½" BSP connectors (not supplied), connect the hot supply pipework to the left-hand inlet and the cold supply to the right-hand inlet (**fig.5**).

Note: Enough free play must be left in the pipework to allow withdrawal from the compression fittings.

DO NOT secure the incoming pipes within one metre of the mixer.

Fit the mounting box front plate into the mounting box and secure using the four screws supplied.

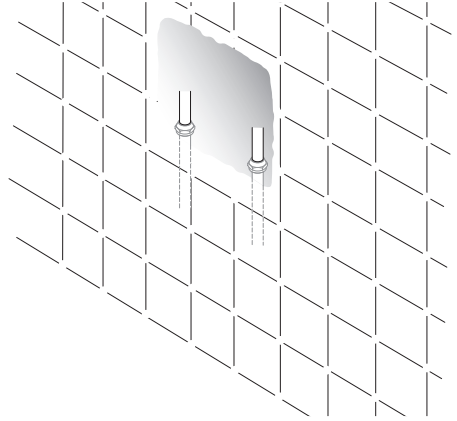

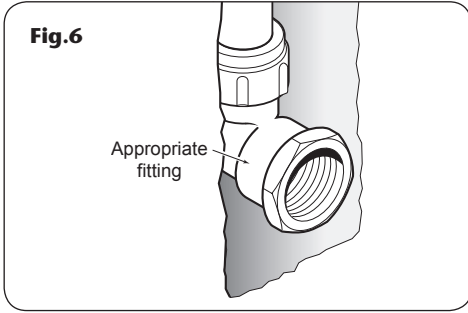

FITTING THE OUTLET PIPEWORK

IMPORTANT: The installer will have to fabricate pipework from the mixer to the showerhead outlet.

Complete the outlet pipework ending in a ½" BSP x 15mm female thread elbow or straight coupler (**fig. 6**).

Note: This fitting is not supplied as variations in installations require the selection of the most suitable fitting.

Open the supplies and test for leaks in all pipework upstream of the valve.

Using the diverter control handle select bath fill. Turn the flow control to the handset position and test for leaks in the pipework.

Remedy any leaks if necessary. Turn off the water supplies.

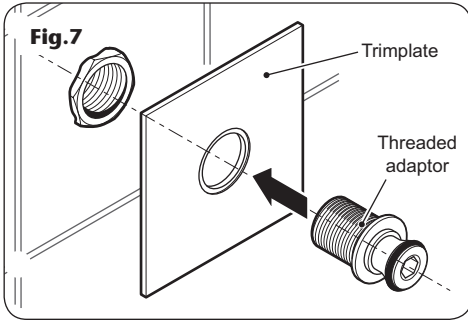

MAKING GOOD

Make good the wall, tiling, etc. around the outlets.

Plaster or tile up to the edge of the mounting box. Make sure the grout lines are flush with the tiles to provide a smooth sealing surface for the cover plate.

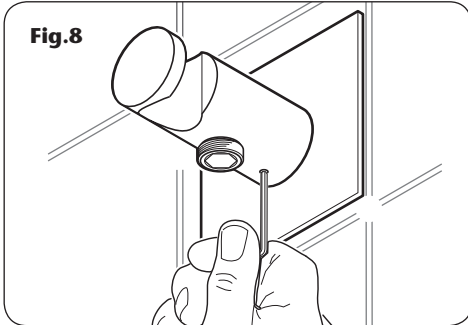

FITTING THE BULKHEAD

Wrap PTFE tap around the threaded adaptor and also apply a small bead of silicon sealant to the back of the bulkhead trim. Insert the threaded adaptor through the bulkhead trim. Screw the adaptor and trim onto the female coupler until tight to the wall and with the trim aligned (**fig. 7**) — the silicon sealant will hold the trim in place. Make sure the adaptor sits properly in the trim recess.

Push fit the handset holder onto the adaptor, making sure the 'O' ring remains in place. Align the holder and secure in position by tightening the grub screw in the holder base (**fig. 8**).

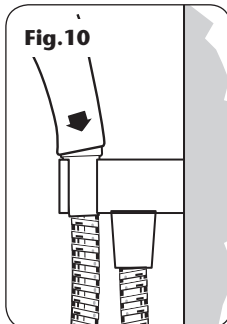
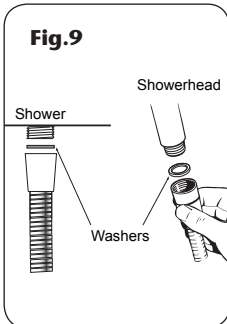

FITTING THE HOSE AND SHOWERHEAD

Screw the flexible hose to the handset outlet and showerhead (**fig.9**), making sure the supplied washers are in place at both ends of the flexible hose.

Place the showerhead into the holder (**fig.10**) and check that it fits correctly.

Note: The holder is slightly tapered and the showerhead and hose will only fit from one direction.

IMPORTANT: It is the conical end of the hose which grips into the holder. The showerhead will not fit in the holder without the hose attached.

FITTING THE TAP SHELF

Connect the flexible coupling to the water inlet at the rear of the tap shelf (**fig.11**).

With the flexible hose connected, place the tap shelf up against the mounting plate so that the holes locate over the spindles (**fig.12**). Slide the two retaining collars through the holes and screw into the spindle sleeves (**fig.13**). Tighten the collars to secure the shelf in place.

Screw the cover trims onto the retaining collars.

Push fit the tap handles onto the spindles. Make sure to fit the handle marked 'H' to the left-hand spindle and the handle marked 'C' to the right-hand spindle (**fig.14**).

Note: It is advisable to run a small bead of silicon sealant around the edge of the cover plate to prevent water entering into the valve cavity.

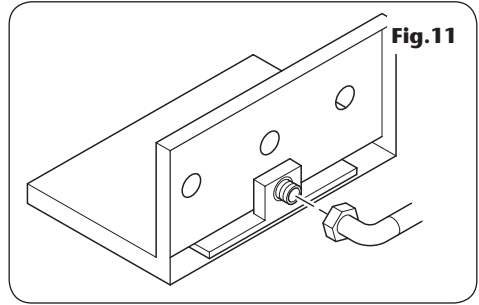

Fig.11

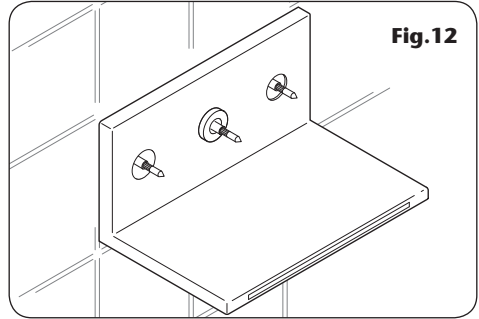

Fig.12

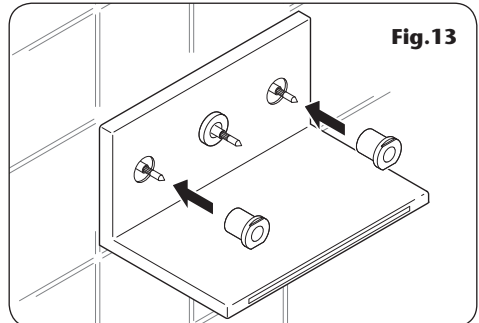

Fig.13

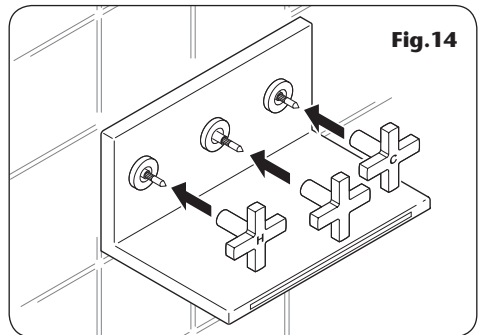
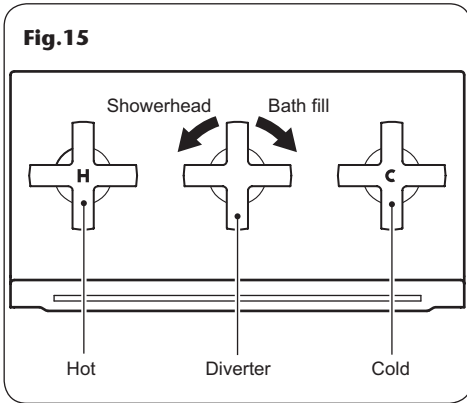

Fig.14



COMMISSIONING

IMPORTANT: Make sure that all pipework has been flushed through before commissioning.

Check that both the hot and cold water supplies are fully open and at (or near to) their design temperature and pressures and are within the requirements as stated.

Turn the diverter handle to bath fill position.

Start the water flow by turning the taps anti-clockwise. Check for leaks and remedy as required.

OPERATION

The mixer works by rotating the tap handles to control flow and temperature. The right-hand tap controls the cold water and the left-hand tap controls the hot water.

To turn the taps on, rotate anti-clockwise. To turn the taps off, rotate clockwise.

The centre handle controls the diverter (**fig.15**). Rotate the handle clockwise for bath filler operation and anti-clockwise for showerhead operation.

CLEANING

When the controls and cover plate require cleaning, care must be taken not to scratch them in the process. Wash away any surface dust before cleaning with soapy water.

SPARE PARTS



Ref	Description	Part No.
1	Mechanical headwork	83309080
2	Diverter cartridge	83309110
3	Tap shelf trim (1 off)	83309170
4	Tap handle — cold	83309050
5	Tap handle — hot	83309040
6	Tap handle — diverter	83309060
7	Flexible hose	28100010

FAULT FINDING

The following can be carried out by a competent person

<i>Problem/Symptom</i>	<i>Cause</i>	<i>Action/Cure</i>
1 Water too hot.	1.1 Not enough cold water flowing through mixer. 1.2 Increase in the ambient cold water temperature. 1.3 Cold water supply blocked. 1.4 High volume of cold water drawn off elsewhere.	1.1.1 Turn cold water control anti-clockwise. 1.1.2 Turn hot water control clockwise. 1.2.1 Turn cold water control anti-clockwise. 1.2.2 Turn hot water control clockwise. 1.3.1 Turn off shower and consult a competent plumber or contact Triton Customer Service. 1.4.1 Reduce the simultaneous demand from the supply.
2 Water too cold.	2.1 Not enough hot water flowing through shower. 2.2 Decrease in the ambient cold water temperature. 2.3 Insufficient hot water supplies from the heating system. 2.4 Hot water supply blocked or restricted.	2.1.1 Turn cold water control clockwise. 2.1.2 Turn hot water control anti-clockwise. 2.1.1 Turn cold water control clockwise. 2.1.2 Turn hot water control anti-clockwise. 2.3.1 Make sure heating appliance is set to maximum or has sufficient stored hot water. 2.3.2 Make sure heating appliance is igniting by trying a hot water tap elsewhere. 2.4.1 Turn off the shower and consult a competent plumber or contact Triton Customer Service.

FAULT FINDING

The following is recommended for a professional qualified installer only

<i>Problem/Symptom</i>	<i>Cause</i>	<i>Action/Cure</i>
3 Water does not flow when another outlet is turned on.	3.1 Water supplies cut off. 3.2 Mixer unit blocked. 3.3 Blockage in pipework. 3.4 System not capable of supplying multiple outlets at the same time.	3.1.1 Check water elsewhere in house and if necessary contact local water company. 3.2.1 Inspect the inlets. Clean if necessary. 3.3.1 Turn off mixer and consult a suitably competent plumber. 3.4.1 Reduce the simultaneous demand. 3.4.2 Check stop/service valves are fully open. 3.4.3 Check if sufficient water pressure.
4 Water too cold.	4.1 Running pressure in excess of maximum recommended.	4.1.1 Fit a pressure reducing valve.
5 Mixer noisy while in use.	5.1 Running pressure in excess of maximum recommended.	5.1.1 Fit a pressure reducing valve.
6 Mixer will not shut off	6.1 Flow control washer worn.	6.1.1 Renew flow control washer.



*A **MORCROS** Company*

Service Policy

In the event of a complaint occurring, the following procedure should be followed:

- 1 Telephone Customer Service on +44 (0) 24 7637 2222 (+44 (0) 84 5762 6591 in Scotland and in Northern Ireland), having available the model number and power rating of the product, together with the date of purchase.
- 2 Triton Customer Service will be able to confirm whether the fault can be rectified by either the provision of a replacement part or a site visit from a qualified Triton service engineer.
- 3 If a service call is required the unit must be fully installed for the call to be booked and the date confirmed. In order to speed up your request, please have your postcode available when booking a service call.
- 4 It is essential that you or an appointed representative (who must be a person of 18 years of age or more) is present during the service engineer's visit and receipt of purchase is shown.
- 5 A charge will be made in the event of an aborted service call by you but not by us, or where a call under the terms of guarantee has been booked and the failure is not product related (i.e. scaling and furring, incorrect water pressure, pressure relief device operation, installation faults).
- 6 If the product is no longer covered by the guarantee, a charge will be made for the site visit and for any parts supplied.
- 7 Service charges are based on the account being settled when work is complete, the engineer will then request payment for the invoice. If this is not made to the service engineer or settled within ten working days, an administration charge will be added.

Replacement Parts Policy

Availability: It is the policy of Triton to maintain availability of parts for the current range of products for supply after the guarantee has expired. Stocks of spare parts will be maintained for the duration of the product's manufacture and for a period of five years thereafter.

In the event of a spare part not being available a substitute part will be supplied.

Payment: The following payment methods can be used to obtain spare parts:

- 1 By post, pre-payment of pro forma invoice by cheque or money order.
- 2 By telephone, quoting credit card (MasterCard or Visa) details.
- 3 By website order, www.tritonshowers.co.uk

TRITON STANDARD GUARANTEE

Triton Plc guarantee this product against all mechanical defects arising from faulty workmanship or materials for a period of five years for domestic use only, from the date of purchase, provided that it has been installed by a competent person in full accordance with the fitting instructions.

Any part found to be defective during this guarantee period we undertake to repair or replace at our option without charge so long as it has been properly maintained and operated in accordance with the operating instructions, and has not been subject to misuse or damage.

This product must not be taken apart, modified or repaired except by a person authorised by Triton Plc. This guarantee applies only to products installed within the United Kingdom and does not apply to products used commercially. This guarantee does not affect your statutory rights.

What is not covered:

- 1 Breakdown due to: *a)* use other than domestic use by you or your resident family; *b)* wilful act or neglect; *c)* any malfunction resulting from the incorrect use or quality of water or incorrect setting of controls; *d)* faulty installation.
- 2 Repair costs for damage caused by foreign objects or substances.
- 3 Total loss of the product due to non-availability of parts.
- 4 Compensation for loss of use of the product or consequential loss of any kind.
- 5 Call out charges where no fault has been found with the appliance.
- 6 The cost of repair or replacement of pressure relief devices, showerheads, hoses, riser rails and/or wall bracket or any other accessories installed at the same time.
- 7 The cost of routine maintenance, adjustments, overhaul modifications or loss or damage arising therefrom, including the cost of repairing damage, breakdown, malfunction caused by corrosion, furring, pipe scaling, limescale, system debris or frost.

Customer Service: ☎ +44 (0) 24 7637 2222

Scottish and Northern Ireland

Customer Service: ☎ +44 (0) 84 5762 6591

Trade Installer Hotline: ☎ +44 (0) 24 7632 5491

Fax: +44 (0) 24 7632 4564

www.aspiranteshowers.co.uk

E mail: technical@triton.plc.uk