

ASPIRANTE

SORGENTE

Monobidet tap



Installation and operating instructions

INSTALLERS PLEASE NOTE THESE INSTRUCTIONS ARE TO BE LEFT WITH THE USER

Fig.1

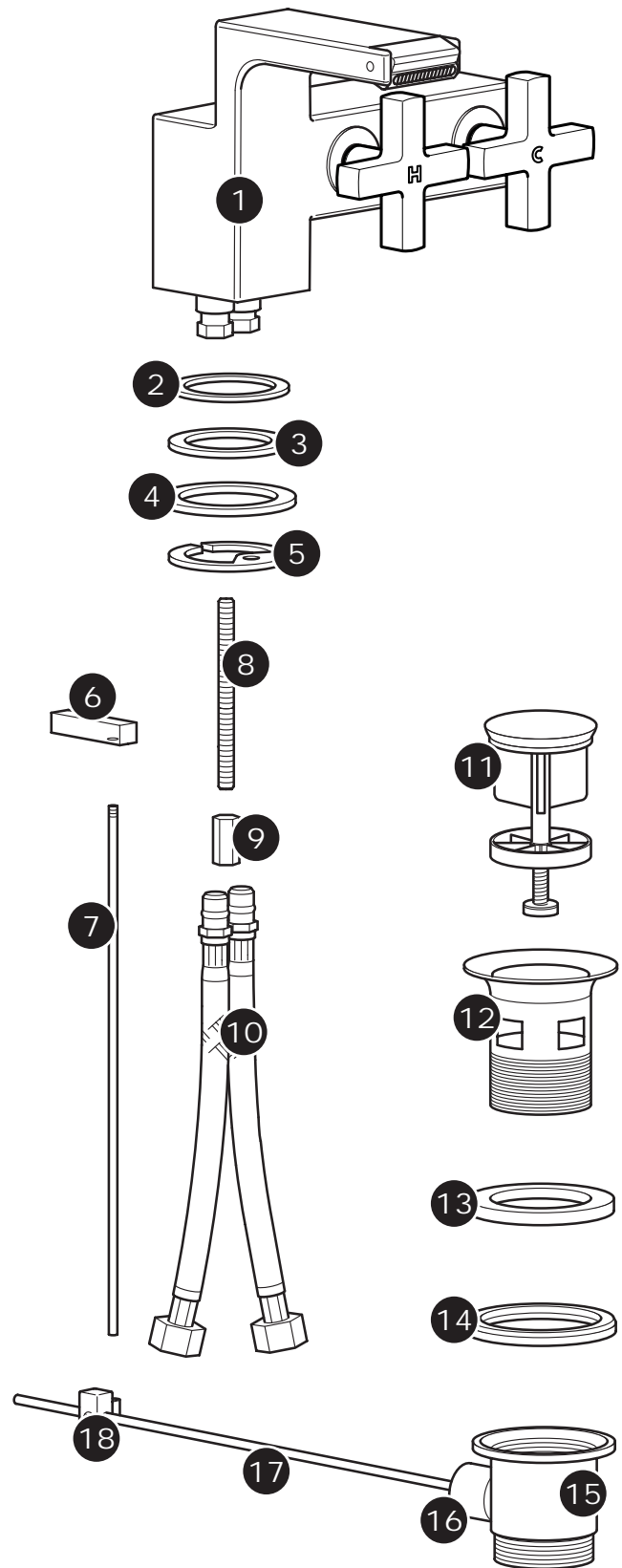

INTRODUCTION

This guide contains all the necessary fitting instructions for your Sorgente monobidet tap.

Please read this guide carefully before beginning your installation.

Note: The Sorgente monobidet tap is suitable for use with single tap hole bidets only.

The tap installation must be carried out by a suitably competent person and in the sequence specified in these instructions.

Care taken during the installation will give a long life and trouble free operation from your tap.

DO NOT choose a position where the tap could become frozen.

Replacement parts can be ordered from Triton Customer Service (*see back page*).

COMPONENTS

The tap set comprises the following items:

1. Monobidet tap
2. Rubber seal
3. Metal washer
4. Rubber seal
5. Horseshoe plate
6. Waste gate control slide
7. Drainage control rod
8. Threaded stud
9. Brass nut
10. Flexible pipes (including sealing washers)
11. Plunger
12. Upper waste outlet
13. Upper silicon seal
14. Lower silicon seal
15. Lower waste outlet
16. Retaining nut
17. Drainage control lever
18. Fixing block

Check that all parts are correct.

SITE REQUIREMENTS

WARNING!

The mixer must not be positioned where it will be subject to freezing conditions.

This mixer is suitable for high water pressures only and should be fitted in accordance with Water Regulations.

Pressure range — 1 bar to 5 bar

Note: For the ideal flow pattern of the mixer, a maximum supply pressure of 3 bar is recommended.

INSTALLATION

Fitting the mixer tap

Screw the two steel braided hoses into the base of the mixer (**fig.2**).

Place the threaded end of the waste gate control slide into the vertical slot at the rear of the tap, making sure that the threaded hole is vertical. Insert the drainage control rod through the unthreaded hole in the rear of the base of the tap body and screw into the threaded hole in the control slide (**fig.3**).

Screw the stud into the threaded hole in the base of the mixer body. Insert the mixer unit into the monobidet hole (**fig.4**).

From the underside of the bidet, insert one of the rubber seals, the metal washer, the remaining rubber seal and the horseshoe plate onto the stud. Make sure that the seals and plates align (**fig.4**).

Screw the brass nut onto the threaded stud and tighten fully to secure the mixer in position.

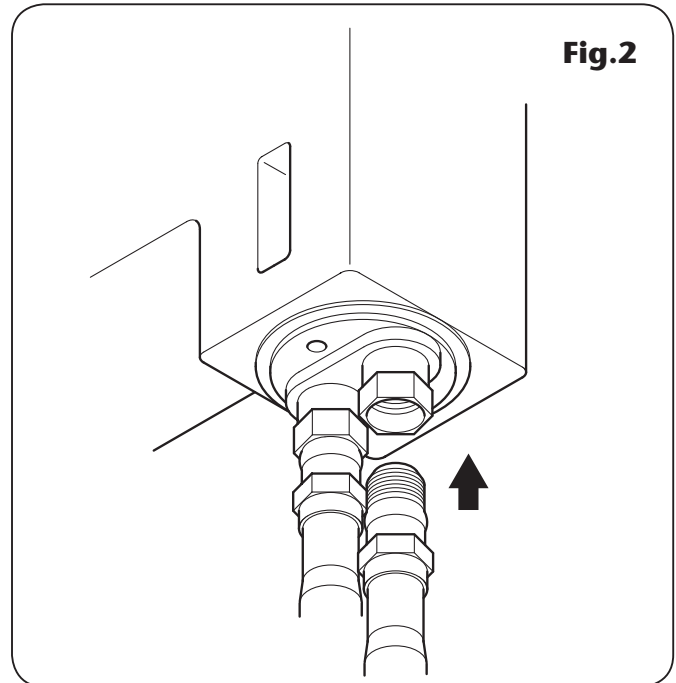

Fig.2

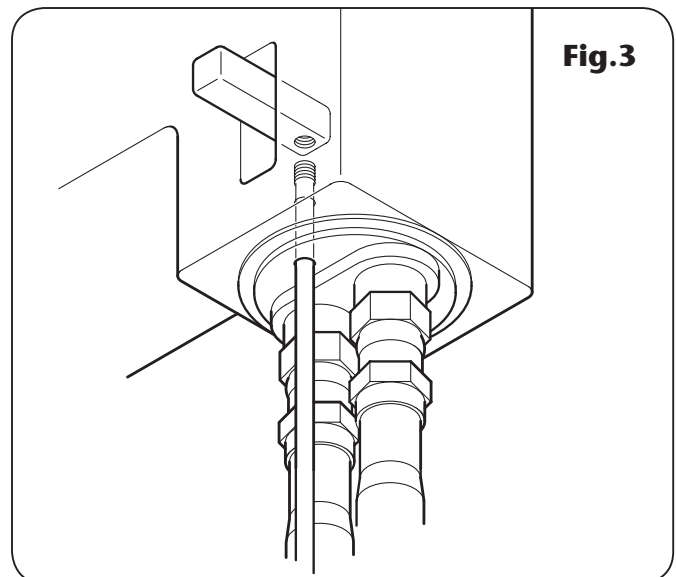

Fig.3

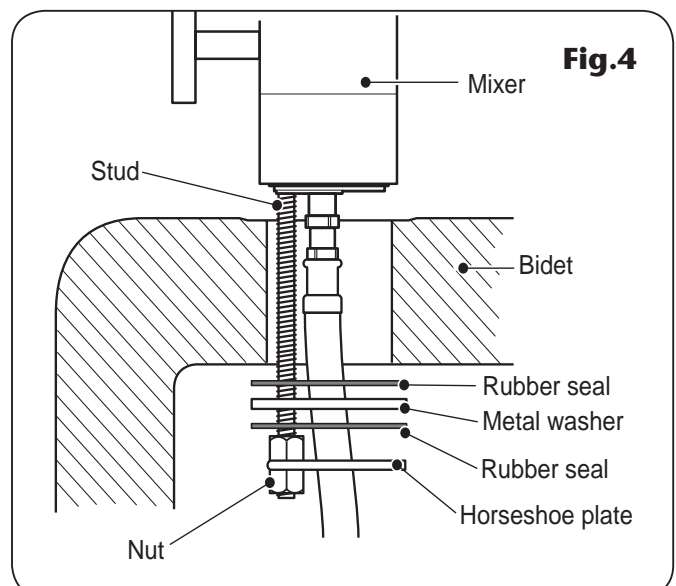
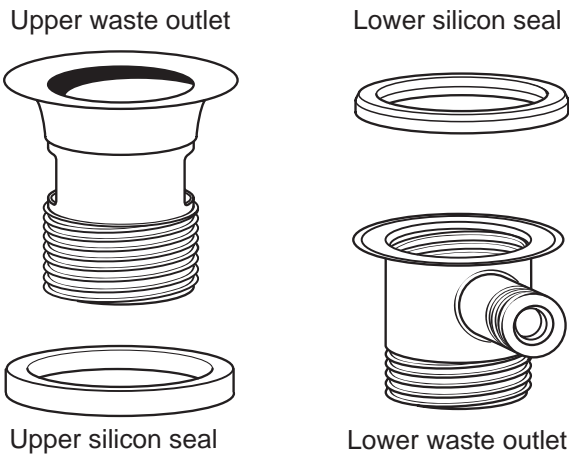

Fig.4

Fig.5



Fitting the waste unit

Remove the plunger from the waste unit. Take the waste assembly apart, as shown in **fig.5**.

Slide the silicon seal onto the upper waste outlet and fit the lower silicon seal onto the lip on the lower waste outlet (**fig.6**).

Insert the control lever through the opening in the side of the lower waste outlet (**fig.6**). Fit the retaining nut and tighten. Finger tight should be sufficient.

From the top of the bidet, place the upper waste fitting into the drainage hole. Screw the lower waste outlet into the upper waste outlet — DO NOT tighten at this stage.

Fig.6

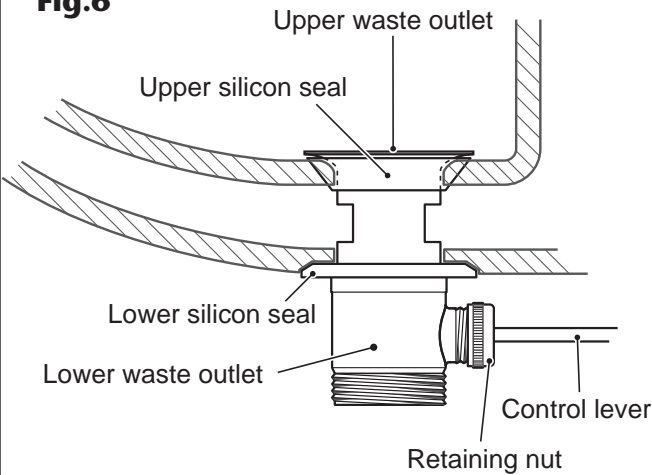

Position the lower fitting such that the control arm faces towards the rear of the bidet. Fully tighten the lower waste unit onto the upper waste unit.

Place the rectangular section of the fixing block onto the control lever and slide into position such that the circular section of the fixing block can receive the drainage control rod (**fig.7**). Tighten the fixing block screws to secure the control rod to the control lever.

Replace the plunger. To alter the plunger gap, remove the plunger from the waste unit and adjust the position of the screw in the plunger base (**fig.8**).

Fig.7

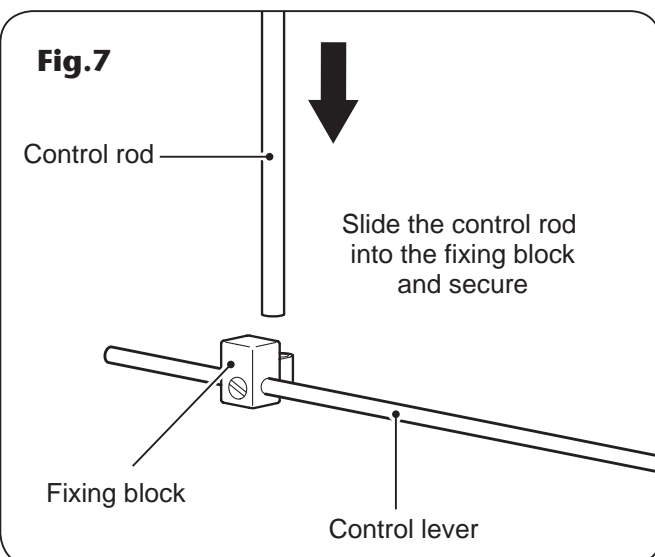

FINISHING THE INSTALLATION

IMPORTANT: Before completing the connection of the water supply to the inlets of the mixer, flush out the system to remove any debris in the pipework. This can be done by connecting a hose to the pipework and turning on the mains water supply long enough to clear the debris to waste.

Make sure the small rubber seal in the end of each of the steel braided hoses is in place. Using standard ½" BSP tap connectors, connect the left-hand steel braided hose to the hot supply and the right-hand hose to the cold supply.

Connect the waste outlet to standard 1¼" waste trap.

OPERATION

The mixer works by rotating the tap handles to control flow and temperature. The right-hand tap controls the cold water and the left-hand tap controls the hot water.

To turn the taps on, rotate anti-clockwise. To turn the taps off, rotate clockwise.

The water outlet is fitted with a swivel head. This can be adjusted by hand to change the direction of the water flow (**fig.9**).

To close the waste gate, lift the waste gate control slide at the rear of the unit (**fig.9**). This will drop the plunger into the waste outlet. To open the waste gate, push down on the control slide.

CLEANING

IMPORTANT: DO NOT use abrasive or solvent cleaning fluids. The mixer unit should be cleaned using a soft cloth and warm water. Any stains should be removed using washing up liquid.

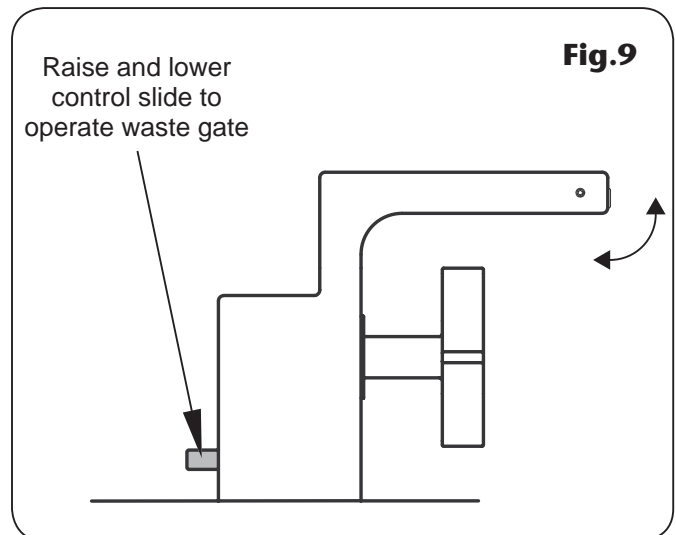
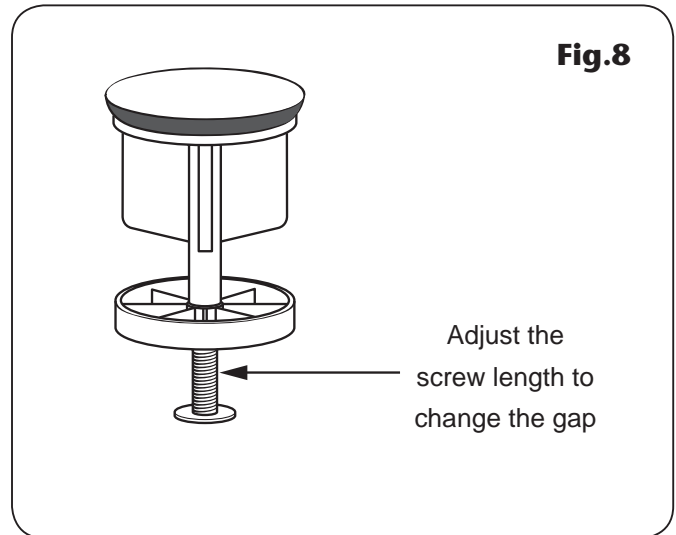

Monobidet tap

SPARE PARTS

Ref. Description

Part No.

- | | |
|--------------------------------|----------|
| 1. Anti-splash | 83309150 |
| 2. ¼ turn ceramic cartridge ½" | 83309070 |
| 3. Trim | 83309160 |
| 4. Monobidet fixing kit | 83309120 |
| 5. Steel braided hose | 83309140 |
| 6. Tap handle – hot | 83309040 |
| 7. tap handle – cold | 83309050 |

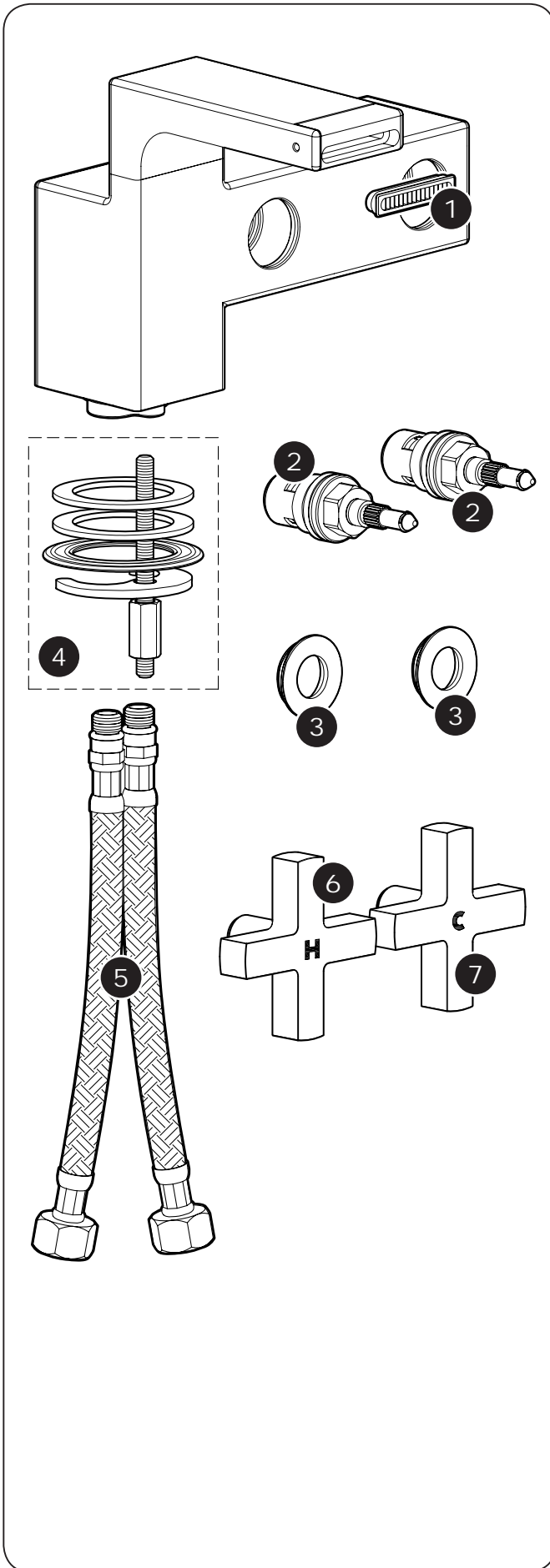



*A **MORCROS** Company*

Service Policy

In the event of a complaint occurring, the following procedure should be followed:

- 1** Telephone Customer Service on +44 (0) 24 7637 2222 (+44 (0) 84 5762 6591 in Scotland and in Northern Ireland), having available the model number and power rating of the product, together with the date of purchase.
- 2** Triton Customer Service will be able to confirm whether the fault can be rectified by either the provision of a replacement part or a site visit from a qualified Triton service engineer.
- 3** If a service call is required the unit must be fully installed for the call to be booked and the date confirmed. In order to speed up your request, please have your postcode available when booking a service call.
- 4** It is essential that you or an appointed representative (who must be a person of 18 years of age or more) is present during the service engineer's visit and receipt of purchase is shown.
- 5** A charge will be made in the event of an aborted service call by you but not by us, or where a call under the terms of guarantee has been booked and the failure is not product related (i.e. scaling and furring, incorrect water pressure, pressure relief device operation, electrical installation faults).
- 6** If the product is no longer covered by the guarantee, a charge will be made for the site visit and for any parts supplied.
- 7** Service charges are based on the account being settled when work is complete, the engineer will then request payment for the invoice. If this is not made to the service engineer or settled within ten working days, an administration charge will be added.

Replacement Parts Policy

Availability: It is the policy of Triton to maintain availability of parts for the current range of products for supply after the guarantee has expired. Stocks of spare parts will be maintained for the duration of the product's manufacture and for a period of five years thereafter.

In the event of a spare part not being available a substitute part will be supplied.

Payment: The following payment methods can be used to obtain spare parts:

- 1** By post, pre-payment of pro forma invoice by cheque or money order.
- 2** By telephone, quoting credit card (MasterCard or Visa) details.
- 3** By website order, www.tritonshowers.co.uk

TRITON STANDARD GUARANTEE

Triton Plc guarantee this product against all mechanical defects arising from faulty workmanship or materials for a period of five years for domestic use only, from the date of purchase, provided that it has been installed by a competent person in full accordance with the fitting instructions.

Any part found to be defective during this guarantee period we undertake to repair or replace at our option without charge so long as it has been properly maintained and operated in accordance with the operating instructions, and has not been subject to misuse or damage. This product must not be taken apart, modified or repaired except by a person authorised by Triton Plc. This guarantee applies only to products installed within the United Kingdom and does not apply to products used commercially. This guarantee does not affect your statutory rights.

What is not covered:

- 1** Breakdown due to: *a*) use other than domestic use by you or your resident family; *b*) wilful act or neglect; *c*) any malfunction resulting from the incorrect use or quality of water or incorrect setting of controls; *d*) faulty installation.
- 2** Repair costs for damage caused by foreign objects or substances.
- 3** Total loss of the product due to non-availability of parts.
- 4** Compensation for loss of use of the product or consequential loss of any kind.
- 5** Call out charges where no fault has been found with the appliance.
- 6** The cost of repair or replacement of pressure relief devices, sprayheads, hoses, riser rails and/or wall bracket or any other accessories installed at the same time.
- 7** The cost of routine maintenance, adjustments, overhaul modifications or loss or damage arising therefrom, including the cost of repairing damage, breakdown, malfunction caused by corrosion, furring, pipe scaling, limescale, system debris or frost.

Customer Service: ☎ +44 (0) 24 7637 2222

Scottish and Northern Ireland

Customer Service: ☎ +44 (0) 84 5762 6591

Trade Installer Hotline: ☎ +44 (0) 24 7632 5491

Fax: +44 (0) 24 7632 4564

www.aspiranteshowers.co.uk

E mail: technical@triton.plc.uk

Triton Plc
Triton Road
Nuneaton
Warwickshire

CV11 4NR